

<b>LINE:</b>	<b>CRANE SCALES</b>
--------------	---------------------

<b>MODEL:</b>	<b>CRS-500/1000 &amp; CRS-1000/2000</b>
---------------	---



USE	CAPACITY AND DIMENSIONS		
	MODEL	CRS-500/1000	CRS-1000/2000
* Steel industry * Mining companies * Steel products manufacturers * etc.	<b>Capacity</b>	500 Kg/1000 lb	1000 kg/2000 lb
	<b>Minimum division</b>	0.2 kg/0.5 lb	0.5 kg/1 lb
	<b>Dimensions</b>	8"W x 5.3"D x 15"H	8"W x 5.3"D x 15"H

### BENEFITS

- |   |   |
|---|---|
| <ul style="list-style-type: none"> <li>• LCD Display with backlight.</li> <li>• HOLD function</li> <li>• Gross/Net weight display</li> <li>• Auto-shut off</li> <li>• Overload &amp; low battery indicator</li> </ul> | <ul style="list-style-type: none"> <li>• Easy-to-change battery</li> <li>• AC/DC (9V/1.5A) Adaptor/charger</li> <li>• Rechargeable battery 6V/10Ah</li> <li>• Wireless Remote control included, up to 33 ft (10 m) away.</li> </ul> |
|---|---|

**LINE:**

**CRANE SCALES**

**MODEL:**

**CRS-500/1000 & CRS-1000/2000**

**BENEFITS**

**SPECIFICATIONS**



**EASY TO USE**

CRS MODEL makes shipping and receiving operations very easy, saving time and avoiding accidents.



**DO IT YOURSELF**

Only follow the unpack guide and turn on the scale, It's ready to use. No technicians required.



**CONTINUOUS OPERATION UP TO 80 HOURS**

The CRS operates anywhere with a long lasting rechargeable battery.

	<b>CRS - 500/1000</b>	<b>CRS - 1000/2000</b>
Capacity	500kg/1000 lb	1000kg/2000 lb
Minimum division	0.2 kg/0.5 lb	0.5 kg/1 lb
Display	LCD Display	
Rechargeable battery	Included up to 80 hrs of continuous work.	
Maximum tare	250 kg/ 500 lb	500 kg/ 1000 lb
Power supply	110v/60hz (220v/50 hz Optional)	
Operation temperature	14 to 104 °F (-10 to 40 °C)	
Storage temperature	-4 to 122 °F (-20 to 50 °C)	
Net weight	9 lb / 4.5 kg	
Shipping weight	13.6 lb / 6.20 kg	



**HIGHLY-VISIBLE DISPLAY**

It features backlit LCD display and can easily be read in low light and dark conditions.

**RELIABLE:**

Durable cast aluminum construction for heavy duty work.



**WIRELESS REMOTE CONTROL**

Allows scale operation up to 33 ft (10 meters) away.

**DIMENSIONS**

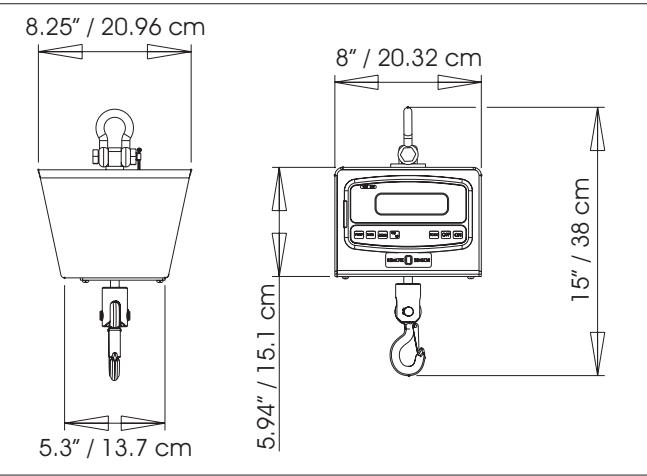

**QUALITY SPECS**



DISTRIBUTED BY

All INFORMATION IS SUBJECT TO CHANGE WITHOUT NOTICE