

StorageBins



TIB-530-A~T-1

A PURPOSE-BUILT ICE BIN – CLEANER BY DESIGN, EASIER TO USE, AND BUILT TO LAST.



Includes True's
exclusive
MAGNASCOOP®



- **Exterior:** TrueTech® clear-coated aluminum with superior corrosion and fingerprint resistance; antimicrobial bin door.
- **Interior:** 100% antimicrobial bin liner.
- **Insulation:** Environmentally friendly, high-density polyurethane foam for maximum ice retention.
- **Design:** Slow-close hinged door and removable ice baffle.
- **Scoop:** Magnetic MagnaScoop® included; stores inside or outside the bin.

| Model | Capacity (lbs) | Dimensions (W x D x H*) | Cubic Volume (ft ³) | Crated Weight (lbs) |
|----------------------------|----------------|---------------------------------------|---------------------------------|---------------------|
| TIB-530-A~T-1 | 515 | 30" x 35" x 50" (762 x 890 x 1270 mm) | 17.4 | 180 |
| Bin Drain: 3/4" Female NPT | | | | |

*Total height includes 6" legs.

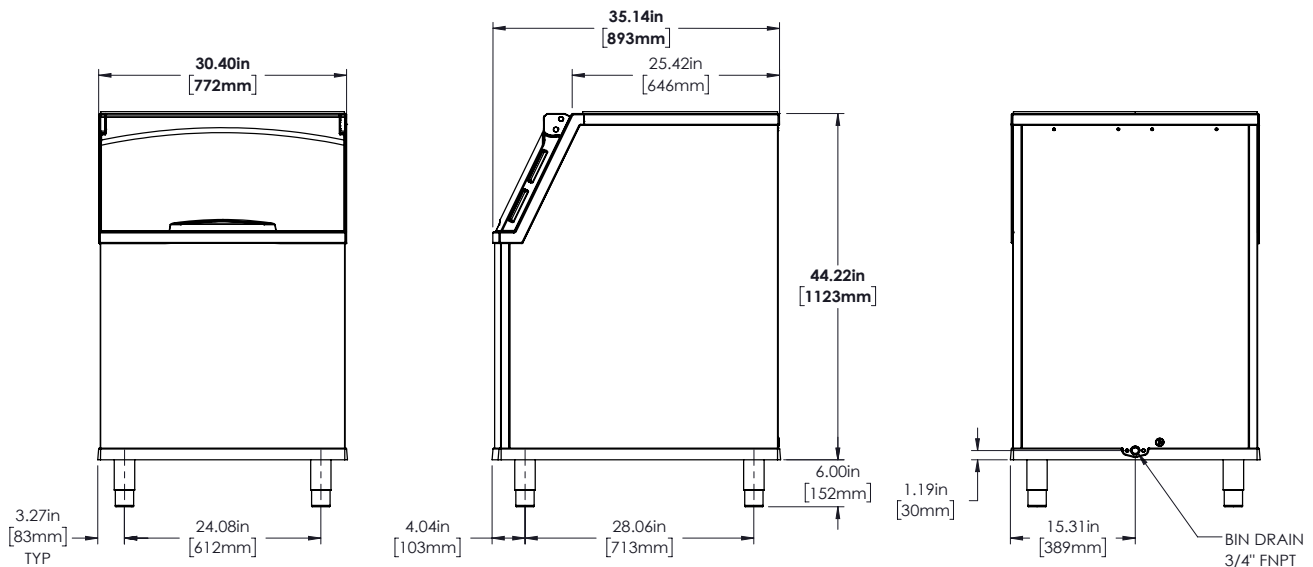

Storage Bin | TIB-530-A~T-1



BIN ADAPTERS

8" Bin Top Adapter (Part #228242)

- Designed for use when installing a 22" machine on a 30" bin.

