



IP 30L RT IP 50L RT BA

Meat mixers - bench



IP 30L RT



IP 50L RT BA

- Compact countertop machines with double paddle allow for a fast, homogenous yet gentle mix of a variety of products, from sausage meat to potato salad, coleslaw and sandwich fillings - with great sales appeal and longer shelf-life
- Forward and reverse mixing action allows for more control over the most delicate products
- Paddles are easily removed for cleaning
- Complete stainless steel construction
- Totally removable tank
- Removable lid with safety microswitch
- Motor with hermetic reducer in oil bath



ON / OFF / REV stainless steel keypad
IP 67 waterproof protection
No voltage release

Features

Technical

- Tank in anodized aluminum profile
- Body and sides in stainless steel AISI 304
- The openable side lid facilitates easy product emptying, fast cleaning and maintenance.

Safety

- A safety interlock stops the machine when opening the lid.
- Overload and no volt release protection

Sanitary

- Removable paddle for an easy and accurate cleaning.

Specifications

Motor IP 30:	0.5 Hp (370W), fan cooled.
Motor IP 50:	1 Hp (750W), fan cooled.
Electrical IP30:	110-120V AC, 60Hz, 1-Phase
Electrical IP50:	110-120V AC, 60Hz, 1-Phase

Controls: ON/OFF/REV stainless steel keypad, IP 67 waterproof protection. No voltage release



IP 30L RT

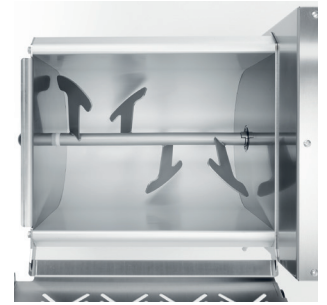

IP 50L RT BA

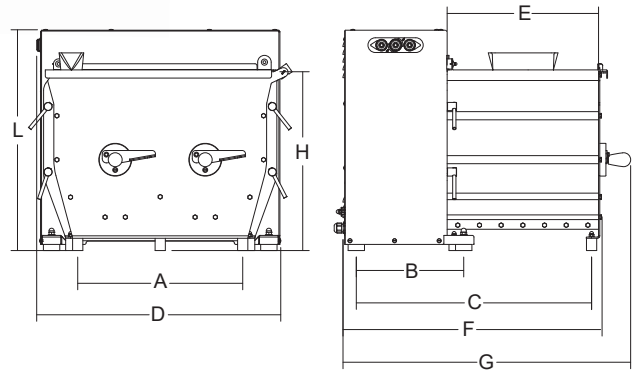

	Power	Power source +/- 10%	Tank dimensions	Capacity	A	B	C	D	E	F	G	H	L	Net weight	Shipping	Gross weight
	watt/HP		inch.	qt	inch.	inch.	inch.	inch.	inch.	inch.	inch.	inch.	inch.	lbs.	inch.	lbs.
IP 30L RT	370/0.5	110-120V, 60Hz, 1-ph	10 ⁵ / ₈ "x14 ⁹ / ₁₆ "	31,7	12 ¹ / ₄ "	10 ⁵ / ₁₆ "	22 ⁴ / ₃ / ₆₄ "	15 ⁵ / ₆₄ "	14 ⁹ / ₁₆ "	24 ⁷ / ₈ "	27 ² / ₃ / ₃₂ "	17 ¹ / ₃ / ₆₄ "	21 ¹ / ₇ / ₆₄ "	115	29 ⁵ / ₈ / ₆₄ " x 25 ¹ / ₃ / ₆₄ " x 30 ⁵ / ₁₆ "	137
IP 50L RT BA	750/1	110-120V, 60Hz, 1-ph	10 ⁵ / ₈ "x14 ⁹ / ₁₆ "	52,8	15 ⁵ / ₆₄ "	10 ² / ₃ / ₆₄ "	22 ⁴ / ₁ / ₆₄ "	23 ¹ / ₅ / ₃₂ "	14 ⁹ / ₁₆ "	24 ⁷ / ₈ "	28 ³ / ₅ / ₆₄ "	17 ¹ / ₃ / ₆₄ "	21 ¹ / ₇ / ₆₄ "	172	33 ⁵ / ₆₄ " x 33 ⁵ / ₆₄ " x 32 ⁴ / ₃ / ₆₄ "	208