

HUSSMANN®

NAV8A

SELF-CONTAINED MERCHANDISER

EVOLVE®

R-290



NAV8A

SELF-CONTAINED SERVICE MERCHANDISER



ADVANTAGES

- Environmentally-friendly R-290 hydrocarbon refrigerant that has zero ozone depletion (ODP) potential and 3 Global Warming Potential (GWP)
- Convenient plug-and-play installation
- Engineered to deliver peak energy efficiency, superior refrigeration performance, and standout merchandising appeal
- Microchannel condenser reduces refrigerant use and is made of corrosion-resistant material
- Designed for NSF Type II ambient conditions (80° F [26.7° C] / 55% RH)



KEY FEATURES

- Stainless steel top and double-tempered argon-filled glass
- External receptacle can be used to connect a scale at the back of the display case
- Standard floor grilles protect the bottom of the case and the products displayed at the base
- Danfoss electronic thermostat control
- Built-in drain in the display case with gas condensate tray for defrosting
- Double rear sliding and removable service door



800.922.1919



www.hussmann.com

NAV8A Self-Contained Merchandiser

AVAILABLE OPTIONS

Exterior Color

- black
- white
- silver

Interior Color

- black
- white
- silver

Bumper Color

- black
- white
- no bumper

SPECIFICATIONS

Models	NAV8A
Applications	packaged product including bakery, beverage, dairy, deli, meat, and produce
Lighting	4000K LED lighting
NEMA Plug	5-15P
Number of Display Levels*	3 display levels; base, one 13 in. shelf, and one 16 in. shelf
Supply Power	120 VAC / 1-phase / 60 Hz
Refrigerant	R-290 (propane)

TECHNICAL INFORMATION



Scan or click QR to access additional resources at hussmann.com

Available with black, white, or silver interior and exterior.

DIMENSIONS

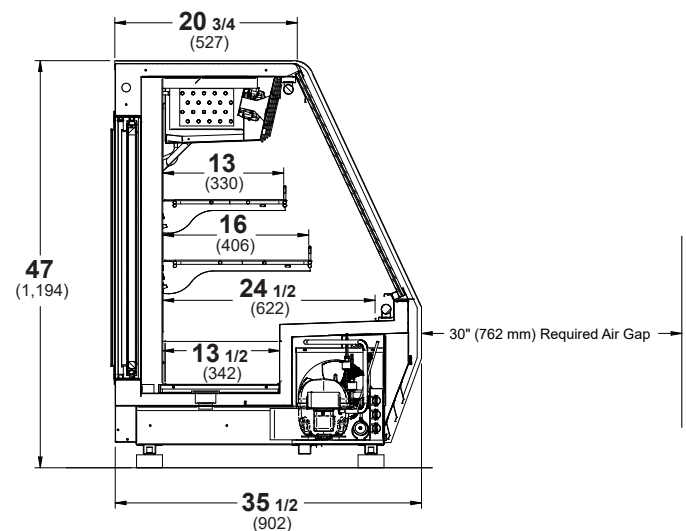

Model	NAV8A
Length	99 3/8 (2,524)

NOTE Dimensions are in Inches (millimeters)

NOTE: Use Hussmann's technical data sheets to get dimensions for all store layout purposes.

NOTE: These merchandisers are designed for displaying products in air-conditioned stores where temperature is maintained at or below the ANSI / NSF-7 specified level and relative humidity is maintained at or below 55%.

We reserve the right to change or revise specifications and product design in connection with any feature of our products. Such changes do not entitle the buyer to corresponding changes, improvements, additions, or replacements for equipment previously sold or shipped. For additional resources, contact your representative or visit www.hussmann.com.

©2025 Hussmann Corporation

HUSSMANN®

Hussmann Corporation
12999 St. Charles Rock Rd.
Bridgeton, MO 63044-2483
Ph: 1.800.592.2060

www.hussmann.com

PS_NAV8A_M001188_A_EN