

Hoshizaki America, Inc.

Modular Flaker

Models

F-450MAH(-C)

F-801MAH(-C), MWH(-C)

F-1001MAH(-C), MWH(-C), MRH(-C), MLH(-C)

F-1500MAH(-C), MWH(-C), MRH(-C)

F-2000MWH(-C), MRH(3)(-C), MLH(-C)



“A Superior Degree
of Reliability”

www.hoshizaki.com

INSTRUCTION MANUAL



Issued: 6-3-2013
Revised: 10-4-2013

⚠ WARNING

Only qualified service technicians should install and service the appliance. To obtain the name and phone number of your local Hoshizaki Certified Service Representative, visit www.hoshizaki.com. No installation or service should be undertaken until the technician has thoroughly read this Instruction Manual. Likewise, the owner/manager should not proceed to operate the appliance until the installer has instructed them on its proper operation. Failure to install, operate, and maintain the appliance in accordance with this manual will adversely affect safety, performance, component life, and warranty coverage and may result in costly water damage. Proper installation is the responsibility of the installer. Product failure or property damage due to improper installation is not covered under warranty.

Hoshizaki provides this manual primarily to assist qualified service technicians in the installation, maintenance, and service of the appliance.

Should the reader have any questions or concerns which have not been satisfactorily addressed, please call, send an e-mail message, or write to the Hoshizaki Technical Support Department for assistance.

Phone: 1-800-233-1940; (770) 487-2331

Fax: 1-800-843-1056; (770) 487-3360

E-mail: techsupport@hoshizaki.com

HOSHIZAKI AMERICA, INC.

618 Highway 74 South

Peachtree City, GA 30269

Attn: Hoshizaki Technical Support Department

NOTE: To expedite assistance, all correspondence/communication **MUST** include the following information:

- Model Number _____
- Serial Number _____
- Complete and detailed explanation of the problem.

IMPORTANT

This manual should be read carefully before the appliance is installed and operated. Read the warnings and guidelines contained in this manual carefully as they provide essential information for the continued safe use and maintenance of the appliance. Retain this manual for any further reference that may be necessary.

CONTENTS

| | |
|--|----|
| Important Safety Information | 5 |
| I. Specifications..... | 7 |
| A. Electrical and Refrigerant Data | 7 |
| 1. F-450MAH(-C)..... | 7 |
| 2. F-801M_H(-C)..... | 7 |
| 3. F-1001M_H(-C) | 8 |
| 4. F-1500M_H(-C)..... | 8 |
| 5. F-2000M_H(3)(-C) | 9 |
| B. Dimensions/Connections | 10 |
| 1. Air-Cooled Models (MAH(-C)) | 10 |
| 2. Water-Cooled Models (MWH(-C)) | 11 |
| 3. Remote Models (MRH(3)(-C)) | 12 |
| 4. Low Side, Parallel Rack System Models (MLH(-C)) | 13 |
| 5. Remote Condenser Unit URC-5F (use with F-1001MRH(-C)) | 14 |
| 6. Remote Condenser Unit URC-14F (use with F-1500MRH(-C)) | 14 |
| 7. Remote Condenser Unit URC-22F (use with F-2000MRH(3)(-C)) | 15 |
| II. Installation and Operating Instructions | 16 |
| A. Location | 16 |
| B. Checks Before Installation..... | 16 |
| C. How to Remove Panels | 17 |
| D. Dispenser Unit/Ice Storage Bin and Icemaker Setup | 18 |
| E. Electrical Connection | 19 |
| F. Water Supply and Drain Connections | 21 |
| 1. Icemaker | 22 |
| 2. Water-Cooled Condenser..... | 23 |
| G. Installation of Remote Condenser Unit | 25 |
| 1. Location | 25 |
| 2. Checks Before Installation..... | 26 |
| 3. Setup | 26 |
| 4. Line Set Size and Refrigerant Charge | 26 |
| 5. Line Set Installation | 27 |
| 6. Electrical Connection..... | 30 |
| 7. Stacking Remote Condenser Unit | 31 |
| H. Connection to an R-404A Parallel Rack System..... | 32 |
| 1. Line Set Size and Rack System Requirements..... | 32 |
| 2. Line Set Installation | 32 |
| I. Final Checklist | 35 |
| J. Startup..... | 36 |

| | |
|---|----|
| III. Maintenance | 38 |
| A. Maintenance Schedule..... | 39 |
| B. Cleaning and Sanitizing Instructions | 40 |
| IV. Preparing the Icemaker for Periods of Non-Use | 44 |
| V. Disposal | 46 |

Important Safety Information

Throughout this manual, notices appear to bring your attention to situations which could result in death, serious injury, damage to the appliance, or damage to property.

⚠ WARNING Indicates a hazardous situation which could result in death or serious injury.

NOTICE Indicates a situation which could result in damage to the appliance or property.

IMPORTANT Indicates important information about the installation, use, and care of the appliance.

⚠ WARNING

The appliance should be destined only to the use for which it has been expressly conceived. Any other use should be considered improper and therefore dangerous. The manufacturer cannot be held responsible for injury or damage resulting from improper, incorrect, and unreasonable use. Failure to install, operate, and maintain the appliance in accordance with this manual will adversely affect safety, performance, component life, and warranty coverage and may result in costly water damage.

To reduce the risk of death, electric shock, serious injury, or fire, follow basic precautions including the following:

- Only qualified service technicians should install and service the appliance.
- The appliance must be installed in accordance with applicable national, state, and local codes and regulations.
- Electrical connection must be hard-wired and must meet national, state, and local electrical code requirements. Failure to meet these code requirements could result in death, electric shock, serious injury, fire, or damage.
- The icemaker requires an independent power supply of proper capacity. See the nameplate for electrical specifications. Failure to use an independent power supply of proper capacity can result in a tripped breaker, blown fuse, damage to existing wiring, or component failure. This could lead to heat generation or fire.
- **THE ICEMAKER MUST BE GROUNDED.** Failure to properly ground the icemaker could result in death or serious injury.
- To reduce the risk of electric shock, do not touch the power switch or control switch with damp hands.
- Move the power switch to the "OFF" position and turn off the power supply before servicing. Lockout/Tagout to prevent the power supply from being turned back on inadvertently.
- Do not place fingers or any other objects into the ice discharge opening.
- Do not make any alterations to the appliance. Alterations could result in electric shock, injury, fire, or damage.

⚠ WARNING, continued

- The appliance is not intended for use by persons (including children) with reduced physical, sensory, or mental capabilities, or lack of experience and knowledge, unless they have been given supervision or instruction concerning use of the appliance by a person responsible for their safety.
- Children should be properly supervised around the appliance.
- Do not climb, stand, or hang on the appliance or allow children or animals to do so. Serious injury could occur or the appliance could be damaged.
- Do not use combustible spray or place volatile or flammable substances near the appliance. They might catch fire.
- Keep the area around the appliance clean. Dirt, dust, or insects in the appliance could cause harm to individuals or damage to the appliance.

Additional Warning for Remote Models

- **THE REMOTE CONDENSER UNIT MUST BE GROUNDED.** The power supply and ground connection to the remote condenser unit are supplied from the icemaker. Failure to properly ground the remote condenser unit could result in death or serious injury.
- Wire routing (conduit) and disconnect (if required) must meet national, state, and local electrical code requirements. Failure to meet these code requirements could result in death, electric shock, serious injury, fire, or damage.

NOTICE

- Follow the water supply, drain connection, and maintenance instructions carefully to reduce the risk of costly water damage.
- In areas where water damage is a concern, install in a contained area with a floor drain.
- Install the icemaker in a location that stays above freezing. Normal operating ambient temperature must be within 45°F to 100°F (7°C to 38°C).
- Do not leave the icemaker on during extended periods of non-use, extended absences, or in sub-freezing temperatures. To properly prepare the icemaker for these occasions, follow the instructions in "IV. Preparing the Icemaker for Periods of Non-Use."
- Do not place objects on top of the appliance.
- The dispenser unit/ice storage bin is for ice use only. Do not store anything else in the dispenser unit/ice storage bin.

I. Specifications

A. Electrical and Refrigerant Data

The rating label and nameplate provide electrical and refrigerant data. The rating label can be seen by removing the front panel. The nameplate is located on the rear panel. For certification marks, see the nameplate.

We reserve the right to make changes in specifications and design without prior notice.

1. F-450MAH(-C)

| Single Phase | |
|------------------------------------|---------------------|
| Model Number | F-450MAH(-C) |
| AC Supply Voltage | 115-120/60/1 |
| Compressor | 120V 7.5RLA 54.5LRA |
| Gear Motor | 115V 2.4FLA 1/4HP |
| Fan Motor | 115V 0.85FLA 1/15HP |
| Other | 115V 0.03A |
| Maximum Fuse Size | 20 AMPS |
| Max. HACR Breaker (USA Only) | 20 AMPS |
| Max. Circuit Breaker (Canada Only) | 20 AMPS |
| Minimum Circuit Ampacity | 20 AMPS |
| Design Pressure | HI-427PSI LO-230PSI |
| Refrigerant | 404A 1 LB. |

2. F-801M_H(-C)

| Single Phase | | |
|------------------------------------|-------------------------|-------------------------|
| Model Number | F-801MAH(-C) | F-801MWH(-C) |
| AC Supply Voltage | 115-120/60/1 | 115-120/60/1 |
| Compressor | 120V 7.5RLA 54.5LRA | 120V 7.5RLA 54.5LRA |
| Gear Motor | 120V 3.0FLA 1/4HP | 120V 3.0FLA 1/4HP |
| Fan Motor | 120V 0.85FLA 1/15HP | --- --- --- |
| Other | 120V 0.03A | 120V 0.03A |
| Maximum Fuse Size | 20 AMPS | 20 AMPS |
| Max. HACR Breaker (USA Only) | 20 AMPS | 20 AMPS |
| Max. Circuit Breaker (Canada Only) | 20 AMPS | 20 AMPS |
| Minimum Circuit Ampacity | 20 AMPS | 20 AMPS |
| Design Pressure | HI - 427PSI LO - 230PSI | HI - 427PSI LO - 230PSI |
| Refrigerant | 404A 1 LB. 12 OZ. | 404A 1 LB. 1 OZ. |

3. F-1001M_H(-C)

| Single Phase | | | | |
|------------------------------------|------------------------------------|------------------------------------|---|----------------------------|
| Model Number | F-1001MAH(-C) | F-1001MWH(-C) | F-1001MRH(-C) | F-1001MLH(-C) |
| AC Supply Voltage | 208-230/60/1 (3 wire with neutral) | 208-230/60/1 (3 wire with neutral) | 208-230/60/1 (3 wire with neutral) | 115-120/60/1 |
| Compressor | 208-230V 5.9RLA 46LRA | 208-230V 5.9RLA 46LRA | 208-230V 5.9RLA 46LRA | --- --- --- |
| Gear Motor | 120V 3.0FLA 1/4HP | 120V 3.0FLA 1/4HP | 120V 3.0FLA 1/4HP | 120V 3.0FLA 1/4HP |
| Fan Motor | 115V 0.85FLA 1/15HP | --- --- --- | 120V 3A MAX | --- --- --- |
| Other | 120V 0.03A | 120V 0.03A | 120V 0.53A | 120V 0.53A |
| Maximum Fuse Size | 15 AMPS | 15 AMPS | 15 AMPS | 15 AMPS |
| Max. HACR Breaker (USA Only) | 15 AMPS | 15 AMPS | 15 AMPS | 15 AMPS |
| Max. Circuit Breaker (Canada Only) | 15 AMPS | 15 AMPS | 15 AMPS | 15 AMPS |
| Minimum Circuit Ampacity | 15 AMPS | 15 AMPS | 15 AMPS | 15 AMPS |
| Design Pressure | HI - 427PSI LO - 230PSI | HI - 427PSI LO - 230PSI | HI - 427PSI LO - 230PSI | HI - 427PSI LO - 230PSI |
| Refrigerant | 404A 2 LB. 4.1 OZ. | 404A 12.3 OZ. | 404A Total Refrigerant Charge with Hoshizaki Remote Condenser Unit URC-5F: 4 LB. 1.2 OZ. | 404A |

4. F-1500M_H(-C)

| Single Phase | | | |
|------------------------------------|------------------------------------|------------------------------------|--|
| Model Number | F-1500MAH(-C) | F-1500MWH(-C) | F-1500MRH(-C) |
| AC Supply Voltage | 208-230/60/1 (3 wire with neutral) | 208-230/60/1 (3 wire with neutral) | 208-230/60/1 (3 wire with neutral) |
| Compressor | 208-230V 9.3RLA 56LRA | 208-230V 9.3RLA 56LRA | 208-230V 9.3RLA 56LRA |
| Gear Motor | 120V 5.6FLA 0.54HP | 120V 5.6FLA 0.54HP | 120V 5.6FLA 0.54HP |
| Fan Motor | 115V 0.85FLA 1/15HP | 120V 0.51FLA 8W | Remote: 120V 3A MAX Cabinet: 120V 0.51FLA 8W |
| Other | 120V 0.03A | 120V 0.03A | 120V 0.03A |
| Maximum Fuse Size | 20 AMPS | 20 AMPS | 20 AMPS |
| Max. HACR Breaker (USA Only) | 20 AMPS | 20 AMPS | 20 AMPS |
| Max. Circuit Breaker (Canada Only) | 20 AMPS | 20 AMPS | 20 AMPS |
| Minimum Circuit Ampacity | 20 AMPS | 20 AMPS | 20 AMPS |
| Design Pressure | HI - 427PSI LO - 230PSI | HI - 427PSI LO - 230PSI | HI - 427PSI LO - 230PSI |
| Refrigerant | 404A 2 LB. 5 OZ. | 404A 1 LB. 4 OZ. | 404A Total Refrigerant Charge with Hoshizaki Remote Condenser Unit URC-14F: 9 LB. 9 OZ. |

5. F-2000M_H(3)(-C)

| Single Phase | | | |
|------------------------------------|------------------------------------|---|--------------------------|
| Model Number | F-2000MWH(-C) | F-2000MRH(-C) | F-2000MLH(-C) |
| AC Supply Voltage | 208-230/60/1 (3 wire with neutral) | 208-230/60/1 (3 wire with neutral) | 115/60/1 |
| Compressor | 240V 10.8RLA 96LRA | 240V 10.8RLA 96LRA | --- --- --- |
| Gear Motor | 120V 5.6FLA 0.54HP | 120V 5.6FLA 0.54HP | 120V 5.6FLA 0.54HP |
| Fan Motor | 120V 0.51FLA 8W | 120V 3A MAX | 120V 0.51FLA 8W |
| Other | 120V 0.03A (-C is 0.53A) | 120V 0.03A (-C is 0.53A) | 120V 0.03A (-C is 0.53A) |
| Maximum Fuse Size | 30 AMPS | 30 AMPS | 15 AMPS |
| Max. HACR Breaker (USA Only) | 30 AMPS | 30 AMPS | 15 AMPS |
| Max. Circuit Breaker (Canada Only) | 30 AMPS | 30 AMPS | 15 AMPS |
| Minimum Circuit Ampacity | 30 AMPS | 30 AMPS | 15 AMPS |
| Design Pressure | HI - 460PSI LO - 290PSI | HI - 460PSI LO - 290PSI | HI - 460PSI LO - 290PSI |
| Refrigerant | 404A 2 LB. 6 OZ. | 404A Total Refrigerant Charge with Hoshizaki Remote Condenser Unit URC-22F: 14 LB. 9 OZ. | 404A |

| Three Phase | |
|------------------------------------|---|
| Model Number | F-2000MRH3(-C) |
| AC Supply Voltage | 208-230/60/3 |
| Compressor | 240V 9.0RLA 75LRA |
| Gear Motor | 120V 5.6FLA 0.54HP |
| Fan Motor | 120V 3A MAX |
| Other | 120V 0.03A (-C is 0.53A) |
| Maximum Fuse Size | 20 AMPS |
| Max. HACR Breaker (USA Only) | 20 AMPS |
| Max. Circuit Breaker (Canada Only) | 20 AMPS |
| Minimum Circuit Ampacity | 20 AMPS |
| Design Pressure | HI - 460PSI LO - 290PSI |
| Refrigerant | 404A Total Refrigerant Charge with Hoshizaki Remote Condenser Unit URC-22F: 14 LB. 9 OZ. |

B. Dimensions/Connections

1. Air-Cooled Models (MAH(-C))

Units: mm [in.]

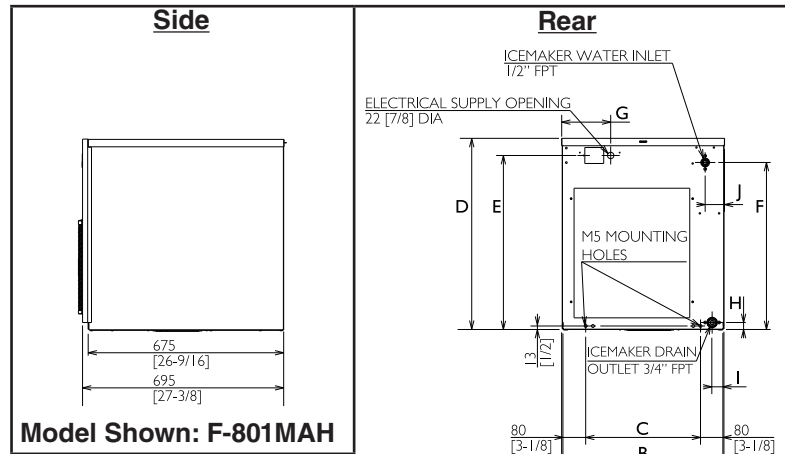

| | F-450MAH(-C) | F-801MAH(-C) | F-1001MAH(-C) | F-1500MAH(-C) |
|----------|----------------|----------------|----------------|----------------|
| A | 560 [22] | 560 [22] | 560 [22] | 770 [30-3/8] |
| B | 550 [21-5/8] | 550 [21-5/8] | 550 [21-5/8] | 766 [30-3/16] |
| C | 395 [15-9/16] | 395 [15-9/16] | 395 [15-9/16] | 602 [23-11/16] |
| D | 558 [21-15/16] | 659 [25-15/16] | 659 [25-15/16] | 874 [34-7/16] |
| E | 507 [19-15/16] | 599 [23-9/16] | 607 [23-7/8] | 820 [32-5/16] |
| F | 475 [18-11/16] | 575 [22-5/8] | 575 [22-5/8] | 730 [28-3/4] |
| G | 130 [5-1/8] | 169 [6-5/8] | 130 [5-1/8] | 133 [5-1/4] |
| H | 48 [1-7/8] | 24 [15/16] | 22 [7/8] | 25 [1] |
| I | 41 [1-5/8] | 41 [1-5/8] | 41 [1-5/8] | 45 [1-3/4] |
| J | 64 [2-1/2] | 67 [2-5/8] | 64 [2-1/2] | 86 [3-3/8] |

Model Shown: F-801MAH

Bottom
F-450/801/1001MAH(-C)

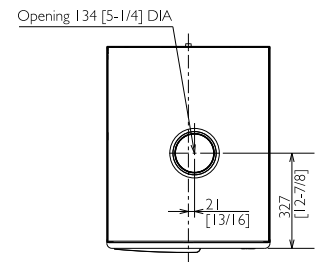

Model Shown: F-801MAH

Bottom
F-1500MAH(-C)

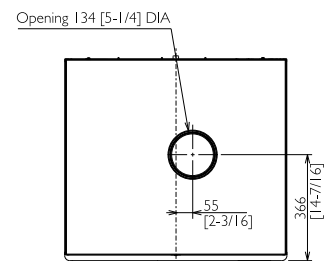

Model Shown: F-1500MAH

NOTICE

- Allow 6" (15 cm) clearance at rear and sides for proper air circulation and ease of maintenance and/or service should they be required. Allow 24" (61 cm) clearance at top to allow for removal of the auger.
- The dispenser unit/ice storage bin opening must accommodate the bottom opening as in the illustration.

2. Water-Cooled Models (MWH(-C))

Units: mm [in.]

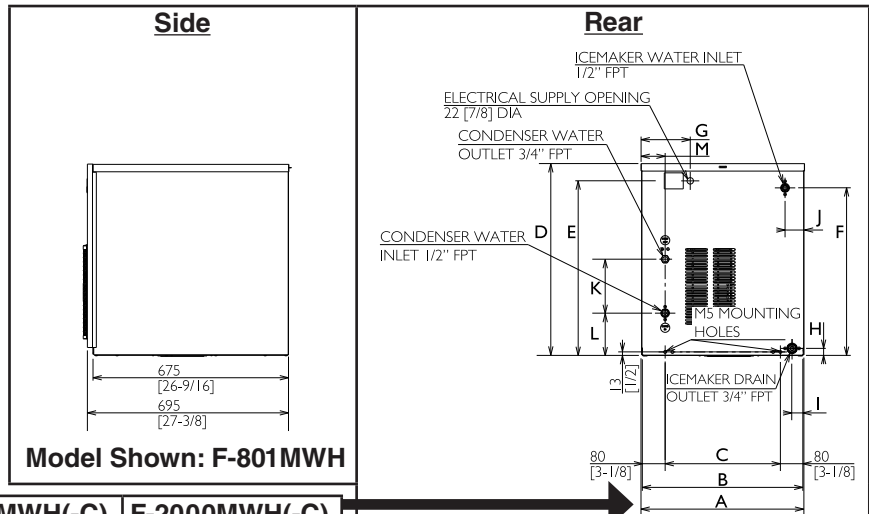

| | F-801MWH(-C) F-1001MWH(-C) | F-1500MWH(-C) | F-2000MWH(-C) |
|----------|-------------------------------|----------------|----------------|
| A | 560 [22] | 770 [30-3/8] | 766 [30-3/16] |
| B | 550 [21-5/8] | 766 [30-3/16] | 762 [30] |
| C | 395 [15-9/16] | 602 [23-11/16] | 602 [23-11/16] |
| D | 659 [25-15/16] | 874 [34-7/16] | 874 [34-7/16] |
| E | 599 [23-9/16] | 811 [31-15/16] | 811 [31-15/16] |
| F | 575 [22-5/8] | 730 [28-3/4] | 705 [27-3/4] |
| G | 169 [6-5/8] | 133 [5-1/4] | 133 [5-1/4] |
| H | 24 [15/16] | 25 [1] | 46 [1-13/16] |
| I | 41 [1-5/8] | 50 [1-15/16] | 52 [2-1/16] |
| J | 67 [2-5/8] | 86 [3-3/8] | 74 [3] |
| K | 185 [7-5/16] | 371 [14-5/8] | 746 [17-5/8] |
| L | 145 [5-11/16] | 136 [5-3/8] | 59 [2-5/16] |
| M | 80 [3-1/8] | 121 [4-3/4] | 133 [5-1/4] |

Model Shown: F-801MWH

Bottom
F-801/1001MWH(-C)

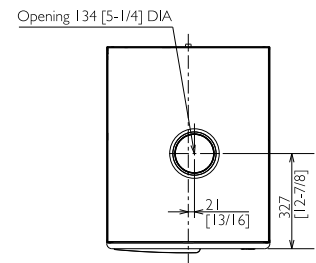

Model Shown: F-801MWH

Bottom
F-1500/2000MWH(-C)

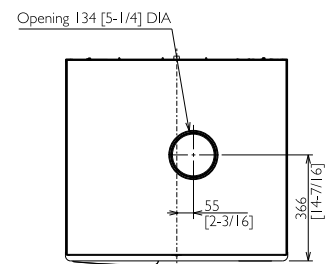

Model Shown: F-1500MWH

NOTICE

- Allow 6" (15 cm) clearance at rear and sides for proper air circulation and ease of maintenance and/or service should they be required. Allow 24" (61 cm) clearance at top to allow for removal of the auger.
- The dispenser unit/ice storage bin opening must accommodate the bottom opening as in the illustration.

3. Remote Models (MRH(3)(-C))

Units: mm [in.]

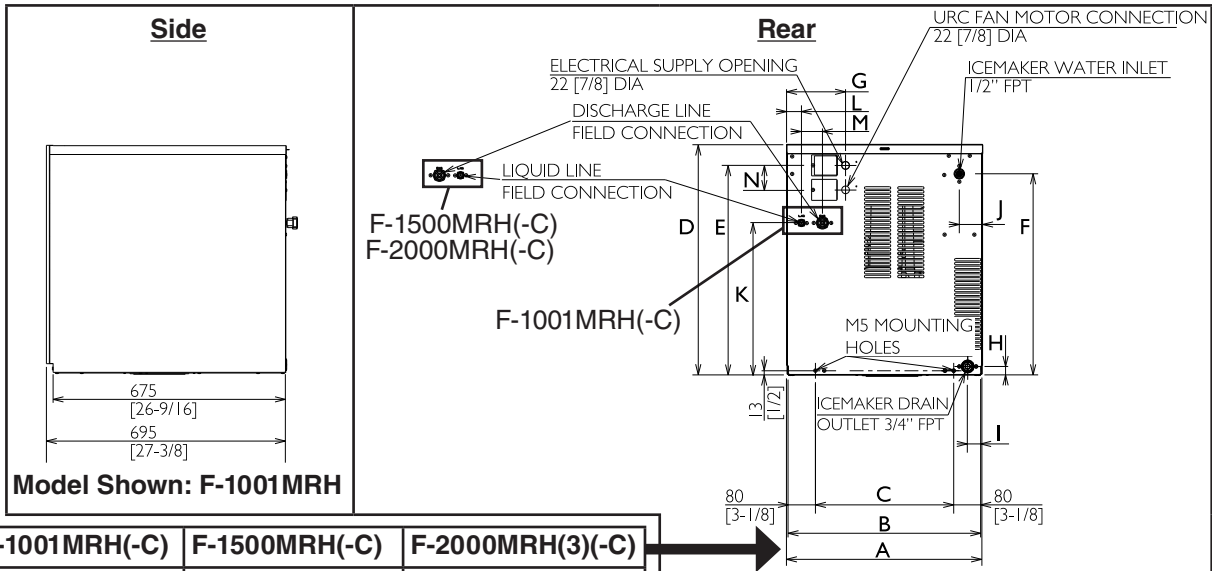

| | F-1001MRH(-C) | F-1500MRH(-C) | F-2000MRH(3)(-C) |
|----------|----------------|----------------|------------------|
| A | 560 [22] | 770 [30-3/8] | 766 [30-3/16] |
| B | 550 [21-5/8] | 766 [30-3/16] | 762 [30] |
| C | 395 [15-9/16] | 602 [23-11/16] | 602 [23-11/16] |
| D | 659 [25-15/16] | 874 [34-7/16] | 874 [34-7/16] |
| E | 607 [23-7/8] | 811 [31-15/16] | 811 [31-15/16] |
| F | 575 [22-5/8] | 730 [28-3/4] | 705 [27-3/4] |
| G | 130 [5-1/8] | 133 [5-1/4] | 133 [5-1/4] |
| H | 22 [7/8] | 25 [1] | 46 [1-13/16] |
| I | 41 [1-5/8] | 50 [1-15/16] | 52 [2-1/16] |
| J | 64 [2-1/2] | 86 [3-3/8] | 74 [3] |
| K | 434 [17-1/16] | 524 [20-5/8] | 524 [20-5/8] |
| L | 40 [1-9/16] | 36 [1-7/16] | 92 [3-5/8] |
| M | 100 [3-15/16] | 62 [2-7/16] | 62 [2-7/16] |
| N | 75 [2-15/16] | 75 [2-15/16] | 75 [2-15/16] |

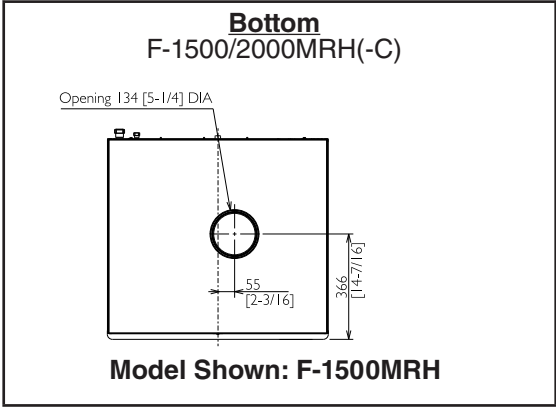
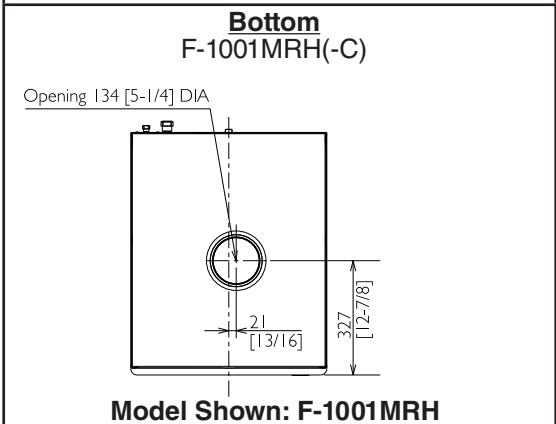

NOTICE

- Allow 6" (15 cm) clearance at rear and sides for proper air circulation and ease of maintenance and/or service should they be required. Allow 24" (61 cm) clearance at top to allow for removal of the auger.
- The dispenser unit/ice storage bin opening must accommodate the bottom opening as in the illustration.

4. Low Side, Parallel Rack System Models (MLH(-C))

Units: mm [in.]

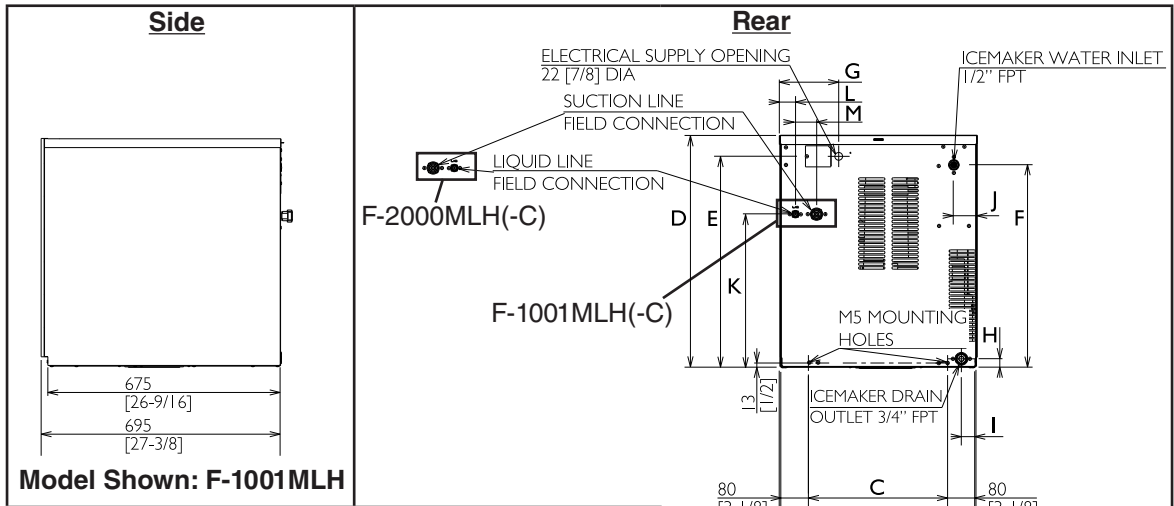

Model Shown: F-1001MLH

| | F-1001MLH(-C) | F-2000MLH(-C) |
|---|----------------|----------------|
| A | 560 [22] | 766 [30-3/16] |
| B | 550 [21-5/8] | 762 [30] |
| C | 395 [15-9/16] | 602 [23-11/16] |
| D | 659 [25-15/16] | 874 [34-7/16] |
| E | 607 [23-7/8] | 811 [31-15/16] |
| F | 575 [22-5/8] | 705 [27-3/4] |
| G | 130 [5-1/8] | 133 [5-1/4] |
| H | 22 [7/8] | 46 [1-13/16] |
| I | 41 [1-5/8] | 52 [2-1/16] |
| J | 64 [2-1/2] | 74 [3] |
| K | 434 [17-1/16] | 524 [20-5/8] |
| L | 40 [1-9/16] | 92 [3-5/8] |
| M | 100 [3-15/16] | 62 [2-7/16] |

Model Shown: F-1001MLH

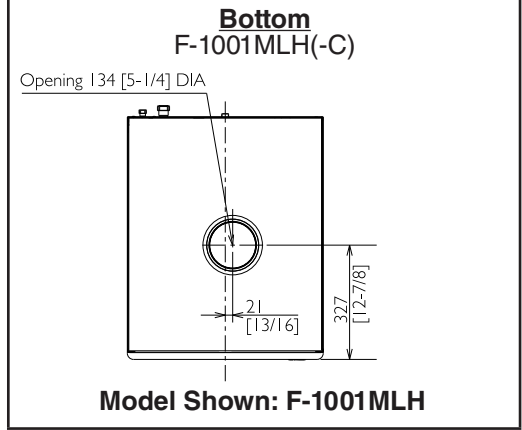

Model Shown: F-1001MLH

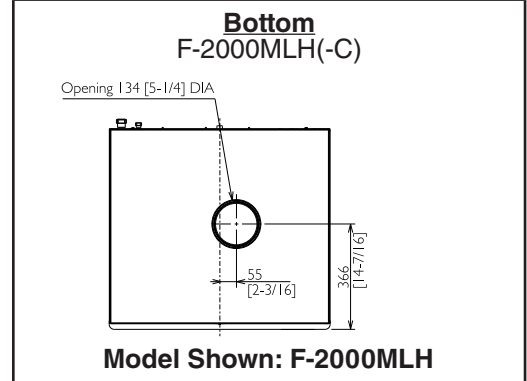

Model Shown: F-2000MLH

NOTICE

- Allow 6" (15 cm) clearance at rear and sides for proper air circulation and ease of maintenance and/or service should they be required. Allow 24" (61 cm) clearance at top to allow for removal of the auger.
- The dispenser unit/ice storage bin opening must accommodate the bottom opening as in the illustration.

5. Remote Condenser Unit URC-5F (use with F-1001MRH(-C))

Units: mm [in.]

NOTICE

Allow 24" (61 cm) clearance at front and rear for proper air circulation and ease of maintenance and/or service should they be required.

Top

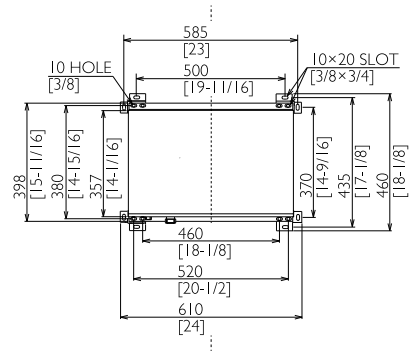

Rear

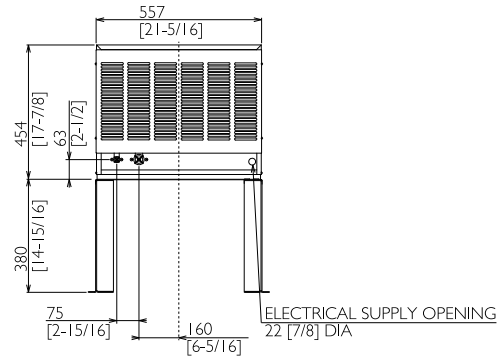

| | |
|-----------------------|---|
| Icemaker Model | URC-5F Heat of Rejection AT 90°F (32°C) WT 70°F (21°C) |
| F-1001MRH | 7,660 BTU/hr |
| F-1001MRH-C | 7,840 BTU/hr |

6. Remote Condenser Unit URC-14F (use with F-1500MRH(-C))

Units: mm [in.]

NOTICE

Allow 24" (61 cm) clearance at front and rear for proper air circulation and ease of maintenance and/or service should they be required.

Top

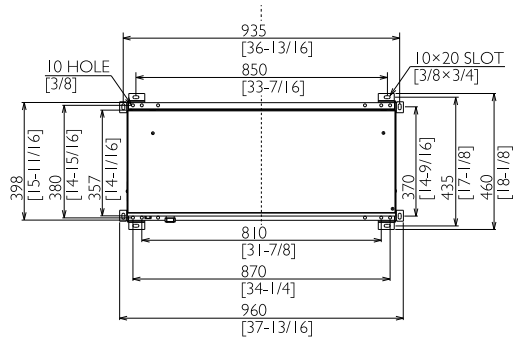

Rear

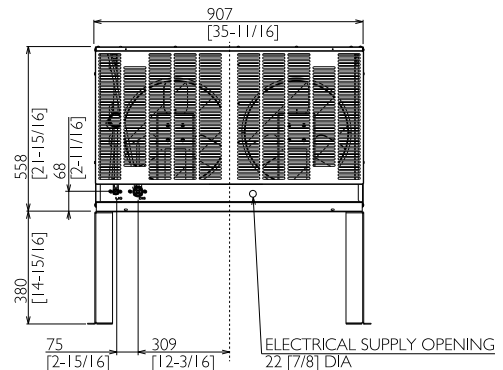

| | |
|-----------------------|--|
| Icemaker Model | URC-14F Heat of Rejection AT 90°F (32°C) WT 70°F (21°C) |
| F-1500MRH(-C) | 13,194 BTU/hr |

7. Remote Condenser Unit URC-22F (use with F-2000MRH(3)-C)

Units: mm [in.]

NOTICE

Allow 24" (61 cm) clearance at front and rear for proper air circulation and ease of maintenance and/or service should they be required.

| Icemaker Model | URC-22F Heat of Rejection |
|----------------|---------------------------|
| | AT 90°F (32°C) |
| | WT 70°F (21°C) |
| F-2000MRH(-C) | 17,690 BTU/hr |
| F-2000MRH3 | 16,890 BTU/hr |
| F-2000MRH3-C | 16,750 BTU/hr |

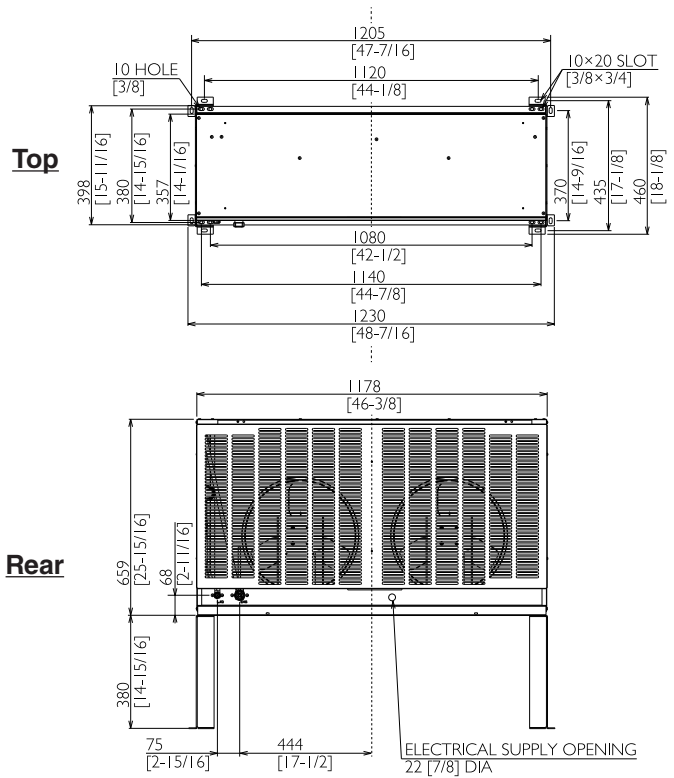

II. Installation and Operating Instructions

⚠ WARNING

- The appliance must be installed in accordance with applicable national, state, and local codes and regulations.
- Failure to install, operate, and maintain the appliance in accordance with this manual will adversely affect safety, performance, component life, and warranty coverage and may result in costly water damage.
- **CHOKING HAZARD:** Ensure all components, fasteners, and thumbscrews are securely in place after installation. Make sure that none have fallen into the dispenser unit/ice storage bin.

A. Location

NOTICE

- The icemaker is not intended for outdoor use. Normal operating ambient temperature must be within 45°F to 100°F (7°C to 38°C); Normal operating water temperature must be within 45°F to 90°F (7°C to 32°C). Operation of the icemaker, for extended periods, outside of these normal temperature ranges may affect icemaker performance.
- The icemaker will not work at sub-freezing temperatures. To prevent damage to the water supply line, drain the icemaker if the air temperature is going to go below 32°F (0°C). See "IV. Preparing the Icemaker for Periods of Non-Use."

- The icemaker should not be located next to ovens, grills, or other high heat producing equipment.
- Allow 6" (15 cm) clearance at rear and sides for proper air circulation and ease of maintenance and/or service should they be required. Allow 24" (61 cm) clearance at top to allow for removal of the auger.
- The location should provide a firm and level foundation for the appliance.

B. Checks Before Installation

- Visually inspect the exterior of the shipping container and immediately report any damage to the carrier. Upon opening the container, any concealed damage should also be immediately reported to the carrier.
- Remove the shipping carton, tape, and packing material. If any are left in the appliance, it will not work properly.
- See the nameplate on the rear panel, and check that your voltage supplied corresponds with the voltage specified on the nameplate.
- Remove the panels to prevent damage when installing the appliance. See "II.C. How to Remove Panels."
- Remove the package containing the accessories.

- Remove the protective plastic film from the panels. If the appliance is exposed to the sun or to heat, remove the film after the appliance cools.
- Check that the refrigerant lines do not rub or touch lines or other surfaces, and that the fan blade (if applicable) turns freely.
- Check that the compressor is snug on all mounting pads.
- Flaker models can be installed on an ice storage bin only. Cubelet models can be installed on either a dispenser unit or an ice storage bin. The ice storage bins listed below are recommended.

| Model Number | Bin Width | Recommended Hoshizaki Ice Storage Bin |
|--------------------------|--------------|---------------------------------------|
| F-450 F-801 F-1001 | 22" or Wider | B-300 Series |
| F-1500 F-2000 | 30" or Wider | B-500 Series |

For further options, contact your local Hoshizaki distributor.

- **NOTICE!** Remote models must be connected to an appropriate remote condenser unit. The remote condenser units listed below are recommended. Connection to a different remote condenser unit will void the warranty unless Hoshizaki approves a different remote condenser unit for your specific application. For further details, contact your local Hoshizaki distributor.

| Model Number | Recommended Hoshizaki Remote Condenser Unit |
|------------------|---|
| F-1001MRH(-C) | URC-5F |
| F-1500MRH(-C) | URC-14F |
| F-2000MRH(3)(-C) | URC-22F |

- On low-side models, an R-404A parallel rack system is needed. See "II.H. Connection to an R-404A Parallel Rack System" for refrigeration circuit details.

C. How to Remove Panels

See Fig. 1

- Front Panel: Remove the screw. Lift up and towards you.
- Top Panel: Lift up at front slightly, push rearward and lift off.
- Side Panels: Remove the screw. Slide forward slightly and lift off.

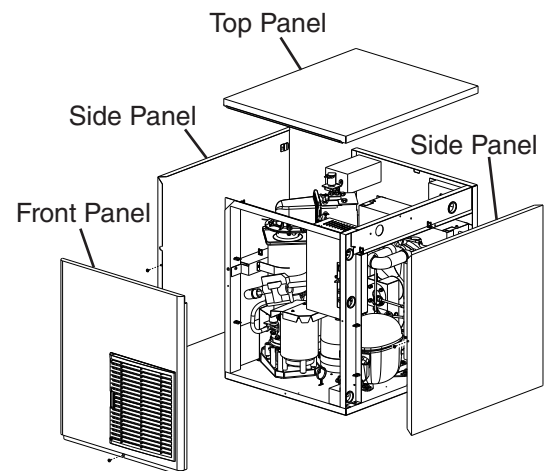

Model Shown: F-801MAH

Fig. 1

D. Dispenser Unit/Ice Storage Bin and Icemaker Setup

⚠ WARNING

The installer must ensure the dispenser unit/ice storage bin is compatible with the icemaker, and the dispenser unit/ice storage bin and icemaker are properly attached and secured.

- 1a) **Dispenser Unit:** Follow the dispenser unit's setup procedure. Note that only cubelet models can be installed on a dispenser unit; flaker models cannot be installed on a dispenser unit.
- 1b) **Ice Storage Bin:** Unpack the ice storage bin and attach the 4 adjustable legs provided (bin accessory) to the bottom of the ice storage bin.
 - 2) Position the dispenser unit/ice storage bin in its permanent location.
 - 3) If required, install an adapter kit or top kit. Contact your local Hoshizaki distributor for recommendations.
 - 4) Level the dispenser unit/ice storage bin in both the left-to-right and front-to-rear directions. If using an ice storage bin, adjust the ice storage bin legs to level.
 - 5) Place the icemaker on top of the dispenser unit/ice storage bin.
- 6a) **Dispenser Unit:** Follow the dispenser unit, adapter kit, or top kit instructions for securing the icemaker. If no instructions are available, secure the icemaker using the mounting brackets provided. Rotate the mounting brackets so that they fit flush to the dispenser unit. See Fig. 2a. Secure the mounting brackets to the icemaker with the bolts provided. Secure the mounting brackets to the dispenser unit with self-tapping screws (not provided). **NOTICE! Use care to avoid damage to dispenser unit components when attaching the mounting brackets.**
- 6b) **Ice Storage Bin:** Follow the ice storage bin, adapter kit, or top kit instructions for securing the icemaker. If no instructions are available, secure the icemaker using the 2 mounting brackets and the bolts provided. See Fig. 2b.

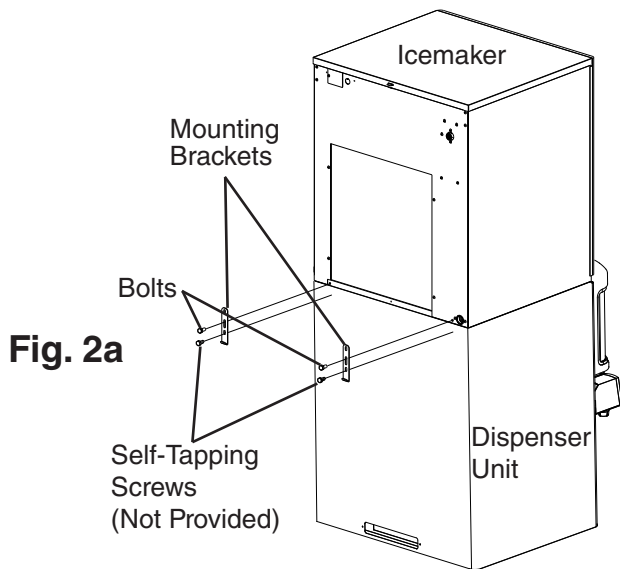

Fig. 2a

Model Shown: F-1500MAH-C

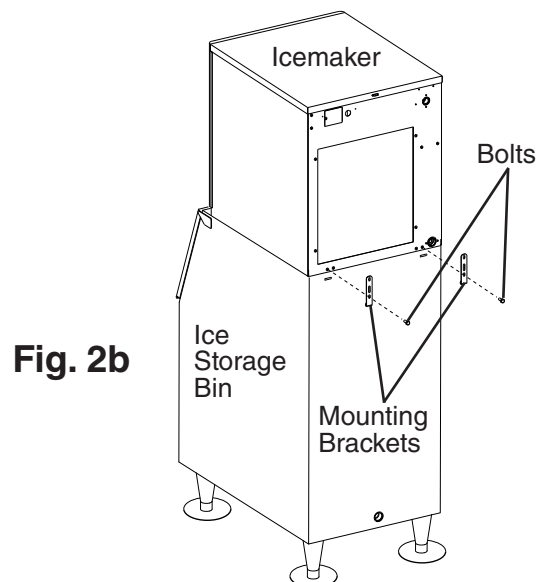

Fig. 2b

Model Shown: F-801MAH

E. Electrical Connection

WARNING

For All Models

- Electrical connection must be hard-wired and must meet national, state, and local electrical code requirements. Failure to meet these code requirements could result in death, electric shock, serious injury, fire, or damage.
- The icemaker requires an independent power supply of proper capacity. See the nameplate for electrical specifications. Failure to use an independent power supply of proper capacity can result in a tripped breaker, blown fuse, damage to existing wiring, or component failure. This could lead to heat generation or fire.
- **THE ICEMAKER MUST BE GROUNDED.** Failure to properly ground the icemaker could result in death or serious injury.
- Electrical connection must be made in accordance with the instructions on the "WARNING" tag, provided with the pig tail leads in the junction box. See Fig. 3.

Additional Warnings for Remote Models

- **THE REMOTE CONDENSER UNIT MUST BE GROUNDED.** Power supply and ground wire to the remote condenser unit are supplied from the icemaker. See "II.G.6. Electrical Connection." Failure to properly ground the remote condenser unit could result in death or serious injury.
- To reduce the risk of electric shock, make all remote condenser unit connections before connecting the icemaker power supply.

NOTICE

On remote models, the appliance must have power for a minimum of 4 hours prior to startup to prevent compressor damage.

- Usually an electrical permit and services of a licensed electrician are required.
- The maximum allowable voltage variation is ± 10 percent of the nameplate rating.
- On single phase models, the white lead must be connected to the neutral conductor of the power source. **NOTICE! Miswiring may result in damage to the icemaker.**
- On three phase models, the transformer's voltage tap switch must be positioned to match incoming voltage at startup.
- **NOTICE! On three phase models, connect the highest incoming voltage supply ("stinger leg") to the power wire dedicated to the compressor. See the wiring label on the icemaker.**
- The opening for the power supply connection is 7/8" DIA to fit a 1/2" trade size conduit.

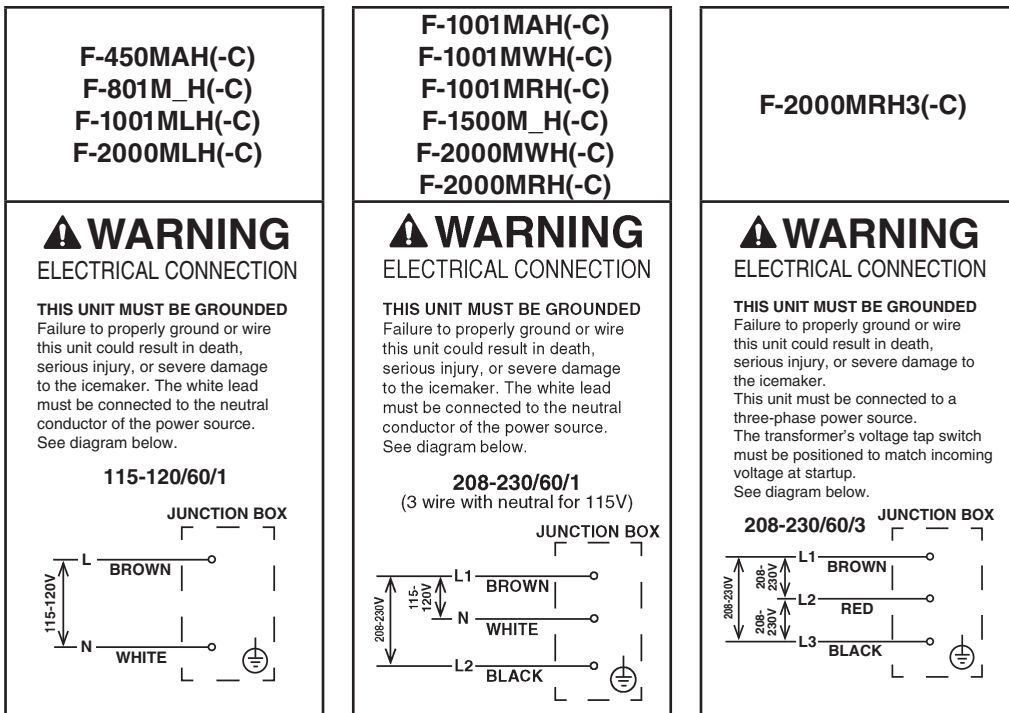

Fig. 3

F. Water Supply and Drain Connections

See Fig. 4, 5, and 6

⚠ WARNING

Water supply and drain connections must be installed in accordance with applicable national, state, and local regulations.

NOTICE

- Normal operating water temperature must be within 45°F to 90°F (7°C to 32°C). Operation of the appliance, for extended periods, outside of this normal temperature range may affect appliance performance.
 - Water supply pressure must be a minimum of 10 PSIG and a maximum of 113 PSIG. If the pressure exceeds 113 PSIG, the use of a pressure reducing valve is required.
 - External filters, strainers, or softeners may be required depending on water quality. Contact your local Hoshizaki Certified Service Representative or local Hoshizaki distributor for recommendations.
- A plumbing permit and services of a licensed plumber may be required in some areas.
 - The icemaker drain line, dispenser unit/ice storage bin drain line, and water-cooled condenser drain line (if applicable) must be run separately.
 - Drain lines must have 1/4" fall per foot (2 cm per 1 m) on horizontal runs to get a good flow. A vented tee connection is also required for proper flow.
 - Drain lines should not be piped directly to the sewer system. An air gap of a minimum of 2 vertical inches (5 cm) must be between the end of the drain pipes from the icemaker, dispenser unit/ice storage bin, and water-cooled condenser (if applicable) and the floor drain.

1. Icemaker

| Icemaker Water Supply Inlet | Minimum Icemaker Water Supply Line Size | Icemaker Drain Outlet | Minimum Icemaker Drain Line Size |
|-------------------------------|---|-------------------------------|---|
| 1/2" Female Pipe Thread (FPT) | 1/4" Nominal ID Copper Water Tubing or Equivalent | 3/4" Female Pipe Thread (FPT) | 3/4" Nominal ID Hard Pipe or Equivalent |

- An icemaker water supply line shut-off valve and drain valve must be installed.
- Be sure there is sufficient extra water supply line and drain line for the appliance to be pulled out for service.

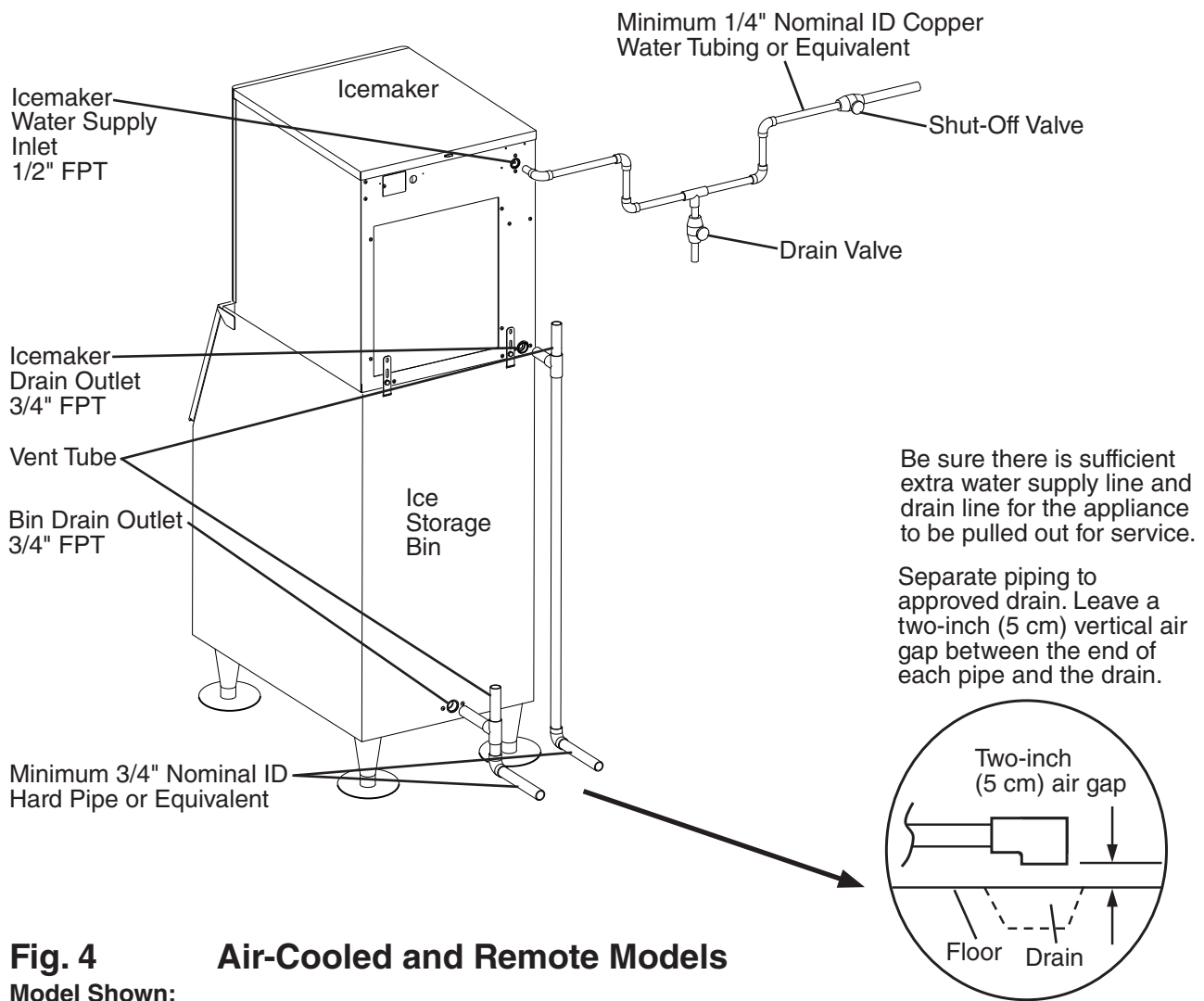

Fig. 4 Air-Cooled and Remote Models
Model Shown:
F-801MAH

2. Water-Cooled Condenser

a) Connection to an Open Drain System

| Condenser Water Supply Inlet | Minimum Condenser Water Supply Line Size | Condenser Drain Outlet | Minimum Condenser Drain Line Size |
|-------------------------------|---|-------------------------------|---|
| 1/2" Female Pipe Thread (FPT) | 1/4" Nominal ID Copper Water Tubing or Equivalent | 3/8" Female Pipe Thread (FPT) | 1/4" Nominal ID Hard Pipe or Equivalent |

- A condenser water supply line shut-off valve and drain valve must be installed.
- In some areas, a back flow preventer may be required in the cooling water circuit.
- In order to maintain the proper high side pressure, the condenser water supply inlet temperature should not drop below 45°F (7°C) and the condenser drain outlet temperature must be in the 104°F to 115°F (40°C to 46°C) range. Once the icemaker installation is complete, confirm the condenser drain outlet temperature 5 minutes after a freeze cycle starts. If the condenser drain outlet temperature is not in the proper range, use a flat blade screwdriver to rotate the adjustment screw on the water-regulating valve until the temperature is in the proper range (rotate counterclockwise to raise temperature or clockwise to lower temperature).

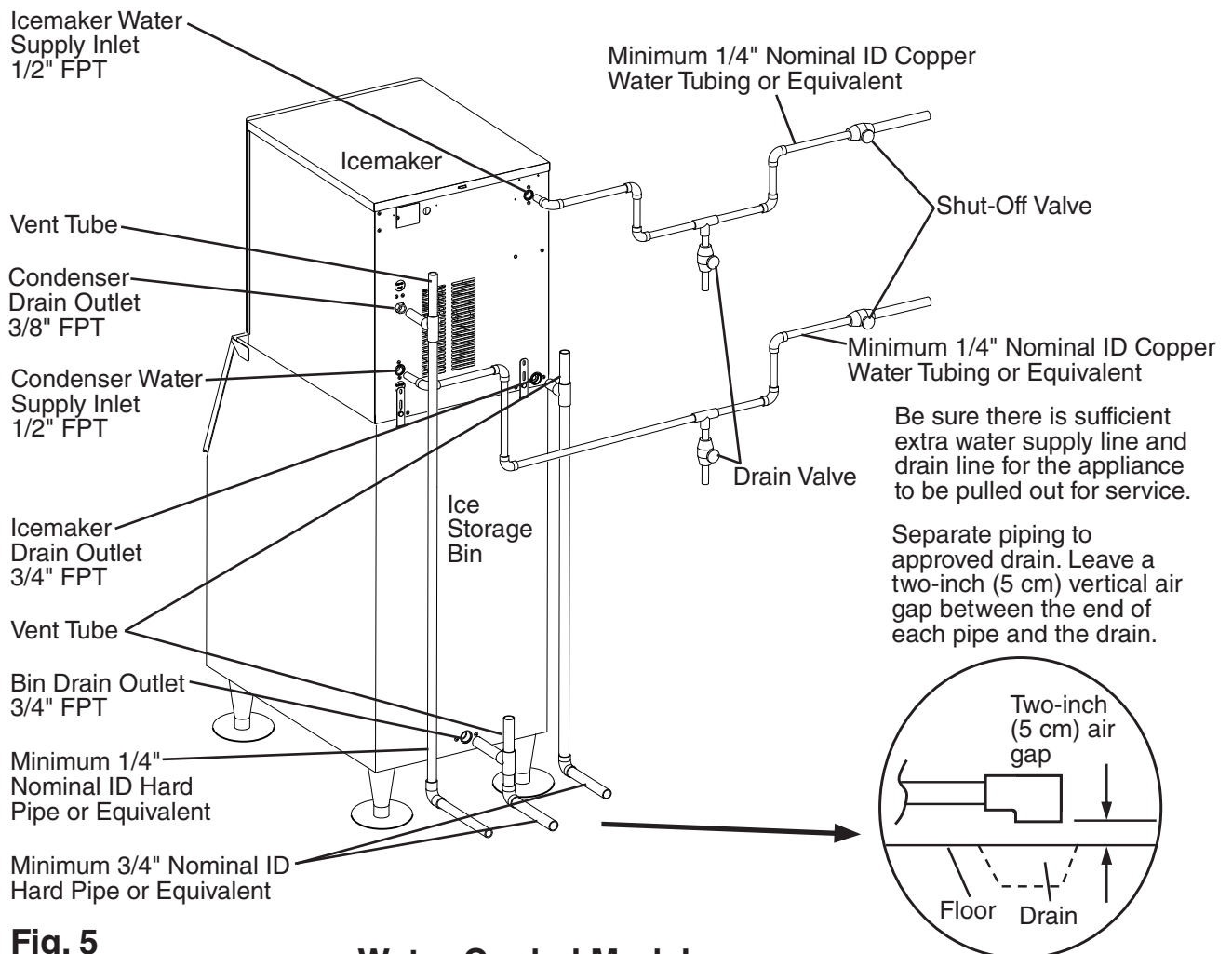

Fig. 5

Model Shown:
F-801MWH

Water-Cooled Models Connection to an Open Drain System

b) Connection to a Closed Loop System

| Condenser Water Supply Inlet | Minimum Condenser Water Supply Line Size | Condenser Return Outlet | Minimum Condenser Return Line Size |
|-------------------------------|---|-------------------------------|---|
| 1/2" Female Pipe Thread (FPT) | 1/4" Nominal ID Copper Water Tubing or Equivalent | 3/8" Female Pipe Thread (FPT) | 1/4" Nominal ID Copper Water Tubing or Equivalent |

- Shut-off valves and drain valves must be installed at both the condenser water supply inlet and condenser return outlet.
- Minimum water flow to the condenser is 4 GPM.
- The pressure differential between the condenser water supply inlet and condenser return outlet must be no less than 10 PSIG.
- When using a glycol blend, the solution mixture must be less than 30% glycol.
- In order to maintain the proper high side pressure, the condenser water supply inlet temperature should not drop below 45°F (7°C) and the condenser return outlet temperature must be in the 104°F to 115°F (40°C to 46°C) range. Once the icemaker installation is complete, confirm the condenser return outlet temperature 5 minutes after a freeze cycle starts. If the condenser return outlet temperature is not in the proper range, use a flat blade screwdriver to rotate the adjustment screw on the water-regulating valve until the temperature is in the proper range (rotate counterclockwise to raise temperature or clockwise to lower temperature).

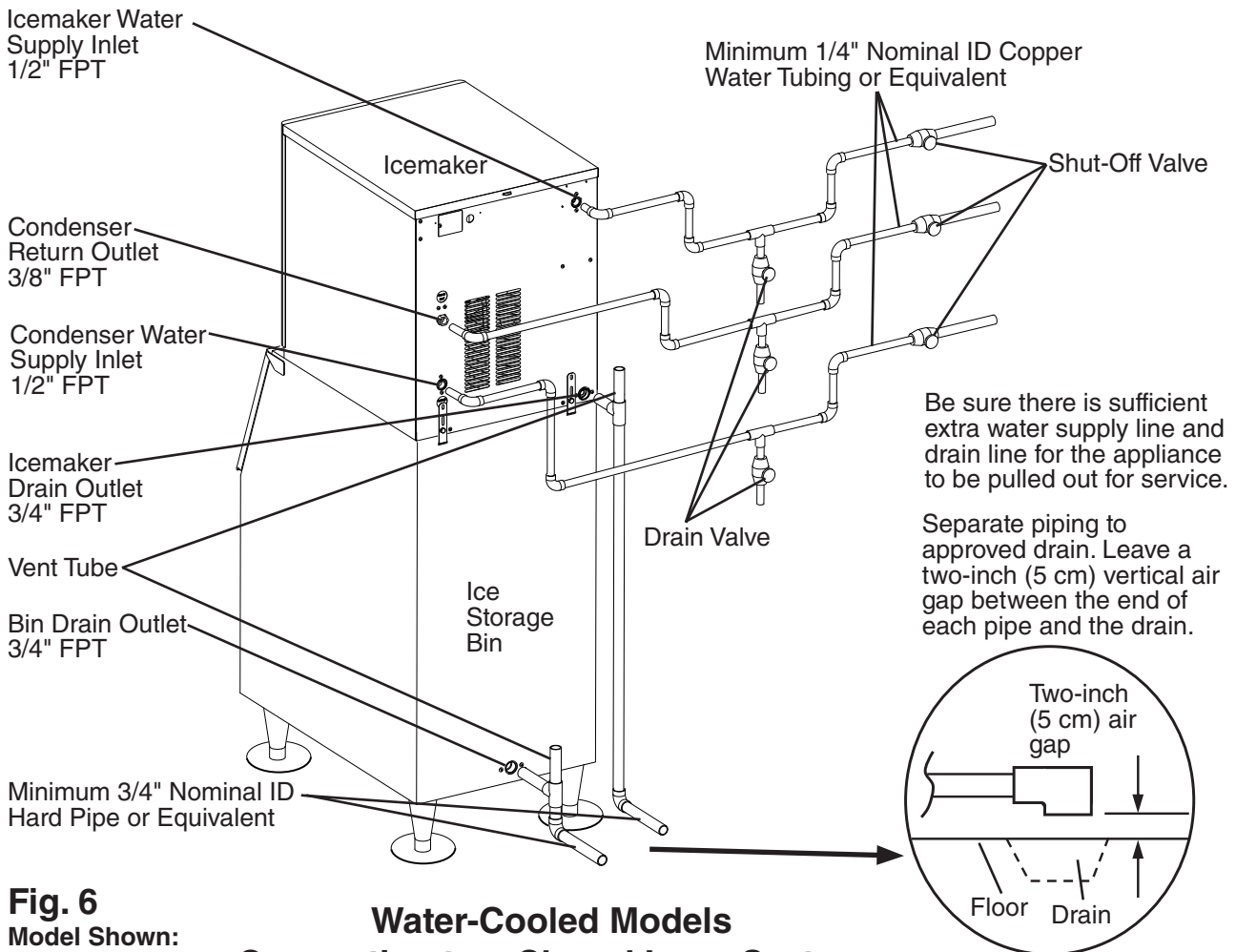

Fig. 6
Model Shown:
F-801MWH
Water-Cooled Models
Connection to a Closed Loop System

G. Installation of Remote Condenser Unit

⚠ WARNING

- Installation of remote condenser unit must be performed by properly trained and EPA-certified service personnel.
- The remote condenser unit must be installed in accordance with applicable national, state, and local codes and regulations.
- Failure to install the remote condenser unit within these guidelines may adversely affect safety, performance, component life, and warranty coverage.
- Power supply and ground wire to the remote condenser unit are supplied from the icemaker. For details, see section "II.G.6. Electrical Connection."

1. Location

NOTICE

- The remote condenser unit is intended for outdoor use. Normal operating ambient temperature must be within -20°F to $+122^{\circ}\text{F}$ (-29°C to $+50^{\circ}\text{C}$). Operation of the remote condenser unit, for extended periods, outside of this normal temperature range may affect appliance performance.
- The maximum line length for the standard line sizes and refrigerant charge is 66' (20 m). With larger line sizes and/or additional refrigerant, the maximum line length is 100' (30.5 m). For details, see "II.G.4 Line Set Size and Refrigerant Charge."
- The maximum vertical distance between the remote condenser unit and the icemaker is 33' (10 m) above or 10' (3 m) below the icemaker. These distances are measured fitting to fitting. See Fig. 7.

The remote condenser unit must be positioned in a permanent site under the following guidelines:

- A firm and flat site.
- A dry and well ventilated area with 24" (61 cm) clearance at front and rear for proper air circulation and ease of maintenance and/or service should they be required. See Fig. 8.

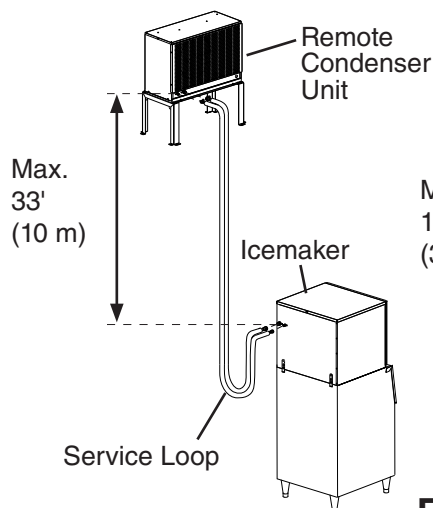

Fig. 7

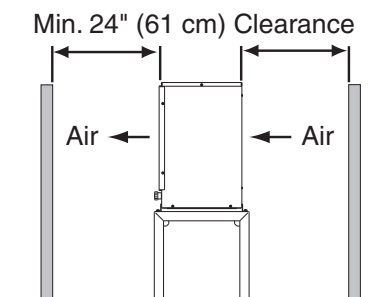
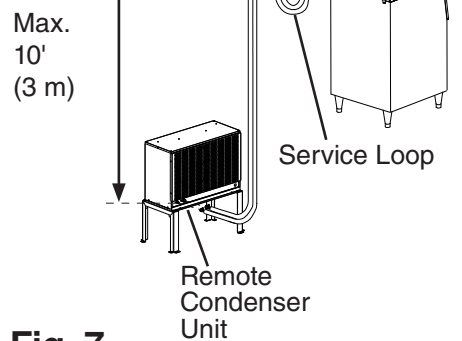

Fig. 8

2. Checks Before Installation

- 1) Remove the shipping carton, tape, and packing material.
- 2) Check that the refrigerant lines do not rub or touch lines or other surfaces, and that the fan blades move freely.

3. Setup

- 1) Secure the legs to the remote condenser unit with the 8 bolts and nuts provided. See Fig. 9.
- 2) The legs have 8 mounting holes. Secure the legs to the permanent site with 8 bolts (not included).

Fig. 9

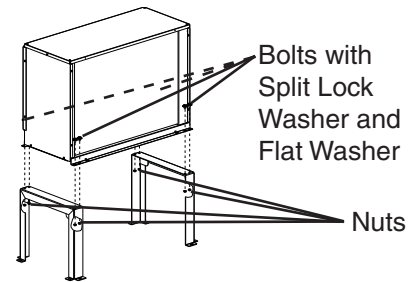

4. Line Set Size and Refrigerant Charge

NOTICE

The icemaker, line set, and remote condenser unit must contain the same type of refrigerant. Mixing of refrigerants will result in improper operation and possible damage to the refrigeration system.

Line Set Size and Refrigerant Charge

| Hoshizaki Icemaker | Hoshizaki Remote Condenser Unit | Line Set Up to 66' (20 m) | | | Line Set Greater than 66' (20 m) Maximum 100' (30.5 m) | | |
|--------------------|---------------------------------|---------------------------|----------------|-------------------|--|----------------|--|
| | | Liquid Line | Discharge Line | Charge Adjustment | Liquid Line | Discharge Line | Charge Adjustment (R-404A) |
| F-1001MRH(-C) | URC-5F | 1/4" OD | 3/8" OD | Not Applicable | 3/8" OD | 1/2" OD | Add 16.5 oz. (468 g) to compensate for larger diameter line sizes, then add 0.4 oz. for each foot over 66' (40 g for each meter over 20 m). Write new total charge on icemaker's rating label. |
| F-1500MRH(-C) | URC-14F | 3/8" OD | 1/2" OD | Not Applicable | 3/8" OD | 1/2" OD | Add 0.4 oz. for each foot over 66' (40 g for each meter over 20 m). Write new total charge on icemaker's rating label. |
| F-2000MRH(3)(-C) | URC-22F | 3/8" OD | 5/8" OD | Not Applicable | 3/8" OD | 5/8" OD | Add 0.4 oz. for each foot over 66' (40 g for each meter over 20 m). Write new total charge on icemaker's rating label. |

5. Line Set Installation

Precharged factory line sets, available as optional equipment from Hoshizaki America, are recommended. For details, see "II.G.5.a) Factory Line Set Installation." Field fabricated line sets are allowed. For details, see "II.G.5.b) Field Fabricated Line Set Installation."

a) Factory Line Set Installation

- 1) Route the factory line set (see "II.G.4 Line Set Size and Refrigerant Charge" for details) from the remote condenser unit to the icemaker. Leave a service loop behind the icemaker to allow the icemaker to be pulled out for service. See Fig. 10. Factory fabricated line sets are precharged and do not need to be evacuated. If the line set is too long or too short, see "II.G.5.a)(1) Factory Line Set Modification."

| NOTICE |
|--|
| <ul style="list-style-type: none">• Ensure that there are no traps and no kinks in the line set. The service loop is not considered an oil trap.• Do not coil extra line set. |

- Ensure that there are no traps and no kinks in the line set. The service loop is not considered an oil trap.
 - Do not coil extra line set.
- 2) Connect the refrigerant lines to the appropriate male fittings on the remote condenser unit first and then at the icemaker. Make a proper connection as follows:
 - a. Remove the protective covers from the male fitting and female coupling.
 - b. Apply Polyol Ester (POE) refrigerant oil or Parker Super O Lube to the entire male fitting, including O-ring, diaphragm, and threads before making the connection. See Fig. 11. **NOTICE! Do not use thread sealant on the fittings. Use POE refrigerant oil or Parker Super O Lube only.**
 - c. Make sure the male fitting and female coupling are properly aligned, then start the connection by hand to ensure that it is not cross threaded.
 - d. Tighten the connection with a wrench until it is tight. At this point, the nut has covered most of the threads on the male fitting.
 - e. Mark a reference line on the female coupling and the remote condenser unit or icemaker panel. Using a backup wrench on the back of the female coupling, tighten the six-sided nut of the female coupling an additional 1/6 turn. See Fig. 12
 - 3) If you lengthened the line set as outlined in "II.G.5.a)(1) Factory Line Set Modification" and it exceeds 66' (20 m), see "II.G.4. Line Set Size and Refrigerant Charge" for proper charging of the appliance.

(1) Factory Line Set Modification

- 1) Recover the line set charge through the Schrader access ports on the Parker quick connect couplings and store it in an approved container. Do not discharge the refrigerant into the atmosphere. Remove the extra line set length or add extra tubing. When adding extra tubing, insulate the additional copper tubes separately.
- 2) Use an electronic leak detector or soap bubbles to check for leaks. Add a trace of refrigerant to the lines through the Schrader access ports on the Parker quick connect couplings (if using an electronic leak detector), and then raise the pressure using nitrogen gas (140 PSIG). **WARNING! Do not use R-404A as a mixture with pressurized air for leak testing.**

- 3) Evacuate through the Schrader access ports on the Parker quick connect couplings and charge with R-404A refrigerant vapor to a pressure of 15 to 30 PSIG. Go to step 2 in "II.G.5.a) Factory Line Set Installation."

b) Field Fabricated Line Set Installation

- 1) Route the copper tube liquid line and copper tube discharge line (see "II.G.4 Line Set Size and Refrigerant Charge" for details) from the remote condenser unit to the icemaker. Leave a service loop behind the icemaker to allow the icemaker to be pulled out for service. See Fig. 10.

| NOTICE |
|---|
| <ul style="list-style-type: none">• Ensure that there are no traps and no kinks in the line set. The service loop is not considered an oil trap.• Do not coil extra line set. Fabricate the line set to the proper length. |

- 2) Insulate the two copper tubes separately.
- 3) Install Parker quick connect couplings on each end. OS-QUICK, a universal quick connect coupling kit available as optional equipment from Hoshizaki America, is recommended. **NOTICE! Before brazing, remove the Schrader valve core from the access port. When brazing, protect the coupling by using a wet cloth to prevent the coupling from overheating. Do not use silver alloy or copper alloy containing arsenic.**
- 4) Allow the coupling to cool, then replace the Schrader valve core.
- 5) Use an electronic leak detector or soap bubbles to check for leaks. Add a trace of refrigerant to the lines through the Schrader access ports on the Parker quick connect couplings (if using an electronic leak detector), and then raise the pressure using nitrogen gas (140 PSIG). **WARNING! Do not use R-404A as a mixture with pressurized air for leak testing.**
- 6) Evacuate through the Schrader access ports on the Parker quick connect couplings and charge with R-404A refrigerant vapor to a pressure of 15 to 30 PSIG.
- 7) Connect the refrigerant lines to the appropriate male fittings on the remote condenser unit first and then at the icemaker. Make a proper connection as follows:
 - a. Remove the protective covers from the male fitting and female coupling.
 - b. Apply Polyol Ester (POE) refrigerant oil or Parker Super O Lube to the entire male fitting, including O-ring, diaphragm, and threads, before making the connection. See Fig. 11. **NOTICE! Do not use thread sealant on the fittings. Use POE refrigerant oil or Parker Super O Lube only.**
 - c. Make sure the male fitting and female coupling are properly aligned, then start the connection by hand to ensure that it is not cross threaded.
 - d. Tighten the connection with a wrench until it is tight. At this point, the nut has covered most of the threads on the male fitting.
 - e. Mark a reference line on the female coupling and the remote condenser unit or icemaker panel. Using a backup wrench on the back of the female coupling, tighten the six-sided nut of the female coupling an additional 1/6 turn. See Fig. 12.
- 8) If the line set exceeds 66' (20 m), see "II.G.4. Line Set Size and Refrigerant Charge" for proper charging of the appliance.

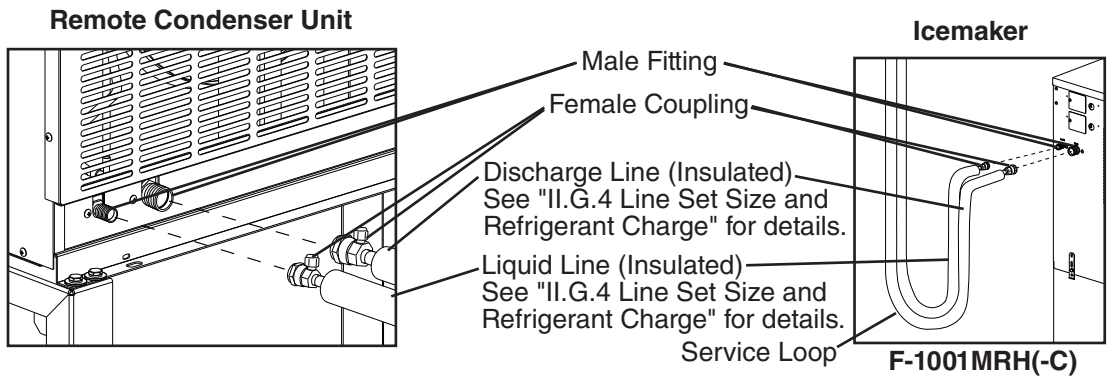

Fig. 10

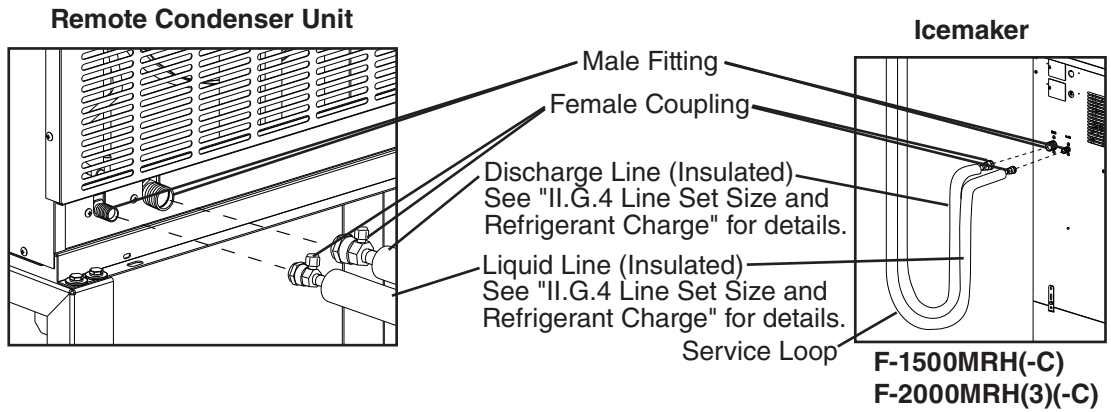

Fig. 11

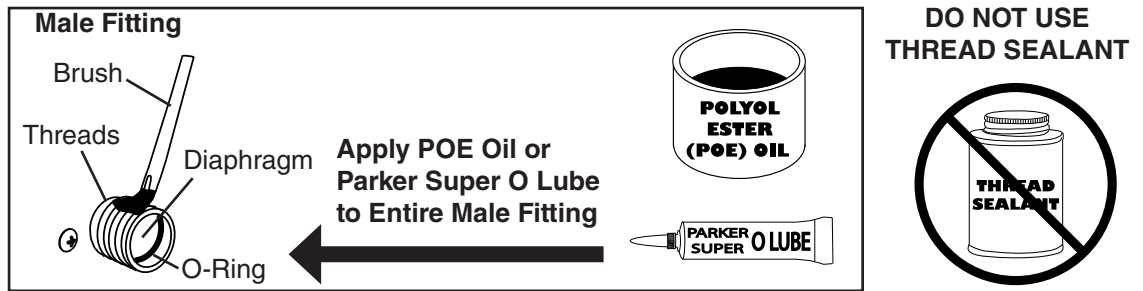
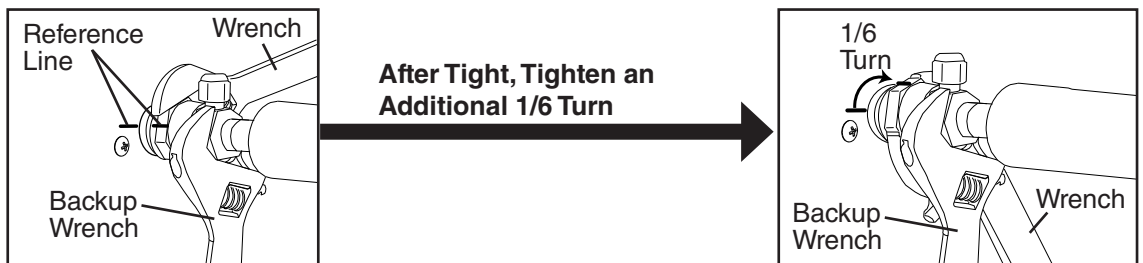

Fig. 12



6. Electrical Connection

⚠ WARNING

- Electrical connection must meet national, state, and local electrical code requirements. Failure to meet these code requirements could result in death, electric shock, serious injury, fire, or damage.
- To reduce the risk of electric shock, make all remote condenser unit connections before connecting the icemaker power supply.
- **THE REMOTE CONDENSER UNIT MUST BE GROUNDED.** Install a ground wire from the icemaker fan motor junction box to the remote condenser unit junction box. Use wire of an appropriate gage and outdoor rating. Failure to properly ground the remote condenser unit could result in death or serious injury.
- Install line and neutral wires from the fan motor leads in the icemaker fan motor junction box to the leads in the remote condenser unit junction box. Use wire of an appropriate gage and outdoor rating.
- Do not connect the fan motor leads in the icemaker to incoming power source. Do not connect the fan motor leads in the icemaker together. Do not allow the leads to contact the junction box walls.
- Do not connect the remote condenser unit to an external power source.

NOTICE

On remote models, the appliance must have power for a minimum of 4 hours prior to startup to prevent compressor damage.

- Usually an electrical permit and services of a licensed electrician are required.
- The opening for the power supply connection is 7/8" DIA to fit a 1/2" trade size conduit.
 - 1) Remove the remote condenser unit louver panel. See Fig. 13.
 - 2) Remove the icemaker fan motor junction box cover. Remove the remote condenser unit junction box cover.

Fig. 13

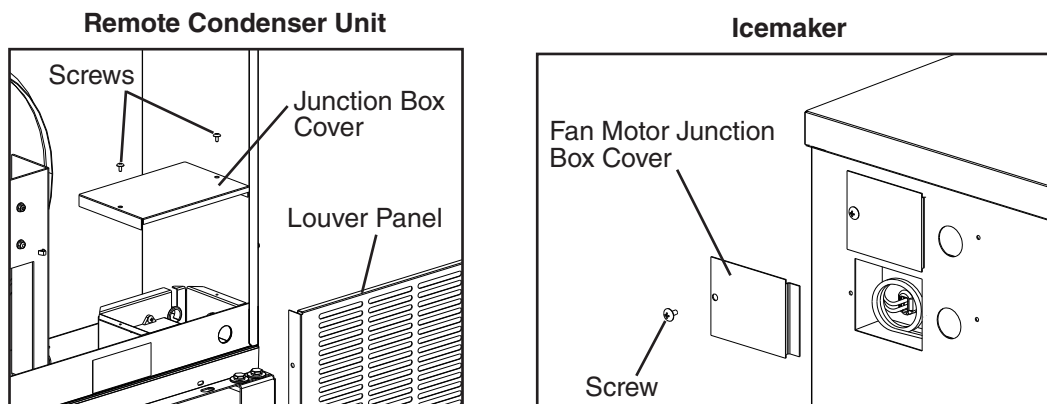

- 3) Install a ground wire from the icemaker fan motor junction box to the remote condenser unit junction box. Use wire of an appropriate gage and outdoor rating.
- 4) Install line and neutral wires from the fan motor leads in the icemaker fan motor junction box to the leads in the remote condenser unit junction box. Use wire of an appropriate gage and outdoor rating.
- 5) Replace the junction box covers and the louver panel in their correct positions.

7. Stacking Remote Condenser Unit

- 1) Install the lower remote condenser unit as described earlier in this section.
- 2) Place the upper remote condenser unit on top of the lower remote condenser unit. See Fig. 14.
- 3) Secure the upper remote condenser unit to the lower remote condenser unit with the 4 screws provided.
- 4) Install refrigerant lines and make electrical connection as described earlier in this section.

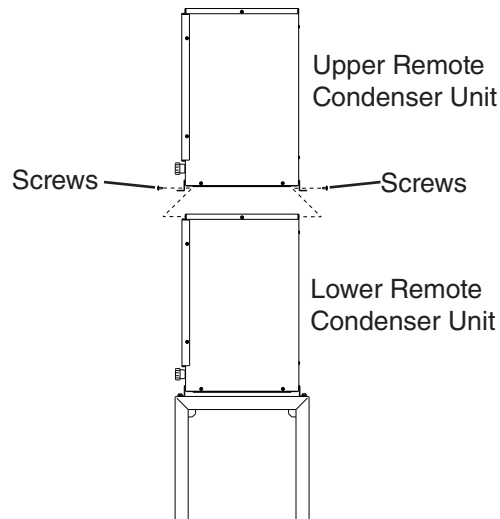

Fig. 14

H. Connection to an R-404A Parallel Rack System

⚠ WARNING

- Installation must be performed by properly trained and EPA-certified service personnel.
- Failure to install the appliance within these guidelines may adversely affect safety, performance, component life, and warranty coverage.

NOTICE

The icemaker, line set, and rack system must contain the same type of refrigerant. Mixing of refrigerants will result in improper operation and possible damage to the refrigeration system.

1. Line Set Size and Rack System Requirements

| Line Set Size and Rack System Requirements | | | | |
|--|-------------|--------------|---|---|
| Hoshizaki Icemaker | Liquid Line | Suction Line | Maximum Load at 90°F (32°C) Ambient 70°F (21°C) Water | Suction Pressure (Evaporator Pressure Regulator (EPR) Valve is factory adjusted. Adjust only if necessary.) |
| F-1001MLH(-C) | 1/4" OD | 3/8" OD | 5,700 BTU/h | 31 PSIG for a -2°F (-19°C) evaporator |
| F-2000MLH(-C) | 3/8" OD | 5/8" OD | 11,600 BTU/h | 22 PSIG for a -14°F (-26°C) evaporator |

- Install a p-trap in the suction line if required by the rack system's instructions.
- The icemaker is shipped with a holding charge of 3.5 oz. of R-404A.
- Charging port-equipped Parker quick connect couplings are needed to connect the line set to the icemaker.

2. Line Set Installation

- 1) Route the copper tube liquid line and copper tube suction line (see "II.H.1 Line Set Size and Rack System Requirements" for details) from the rack system to the icemaker. Leave a service loop behind the icemaker to allow the icemaker to be pulled out for service. See Fig. 15. **NOTICE! Do not coil extra line set. Fabricate the line set to the proper length.**
- 2) Insulate the 2 copper tubes separately.
- 3) Braze the charging port-equipped Parker quick connect couplings to the icemaker end of the copper tubes. Do not connect the charging port-equipped Parker quick connect couplings to the icemaker at this time.
- 4) When using couplings to connect the line set to the rack system, braze them to the rack system end of the copper tubes. Otherwise, braze the line set directly to the rack system. Do not open the rack system service valves at this time.

- 5) Use an electronic leak detector or soap bubbles to check for leaks. Add a trace of refrigerant to the line set copper tubes (if using an electronic leak detector), and then raise the pressure using nitrogen gas (140 PSIG). **WARNING! DO NOT use R-404A as a mixture with pressurized air for leak testing.**
- 6) Evacuate the line set copper tubes through the charging ports on the Parker quick connect couplings and charge with R-404A refrigerant vapor to a pressure of 15 to 30 PSIG.
- 7) Connect the refrigerant lines to the appropriate fittings on the rack system first (if not already brazed on), then at the icemaker.

If the couplings to the rack system are not Parker quick connect couplings, follow the coupling manufacturer's instructions. Make a proper Parker quick connect coupling connection as follows:

- a. Remove the protective covers from the male fitting and female coupling.
 - b. Apply Polyol Ester (POE) refrigerant oil to the entire male fitting, including threads, O-ring, and diaphragm, before making the connection. See Fig. 16. **NOTICE! Do not use thread sealant on the fittings. Use POE refrigerant oil or Parker Super O Lube only.**
 - c. Make sure the male fitting and female coupling are properly aligned, then start the connection by hand to ensure that it is not cross threaded.
 - d. Place a backup wrench on the back of the female coupling, then tighten the connection with a wrench until it is tight. At this point, the nut has covered most of the threads on the male fitting. **NOTICE! Failure to use a backup wrench may result in damage to the line set and possible refrigerant leaks.**
 - e. Mark a reference line on the female coupling and the unit panel. Using a backup wrench on the back of the female coupling, tighten the six-sided nut of the female coupling an additional 1/6 turn. See Fig. 17.
- 8) Open the rack system service valves.

Rack System-Threaded Connection

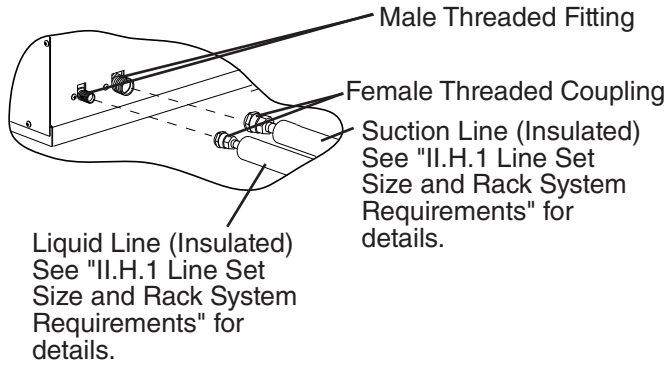

Rack System-Braze Connection

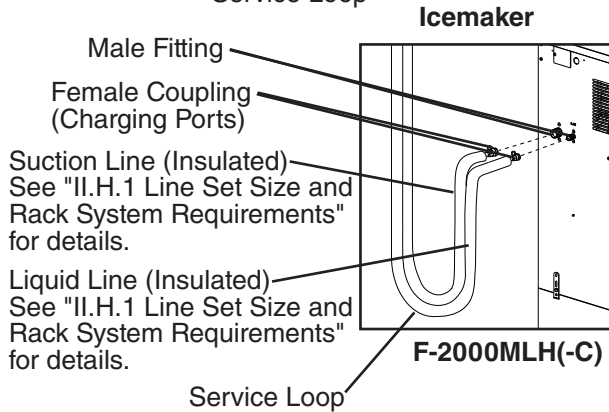
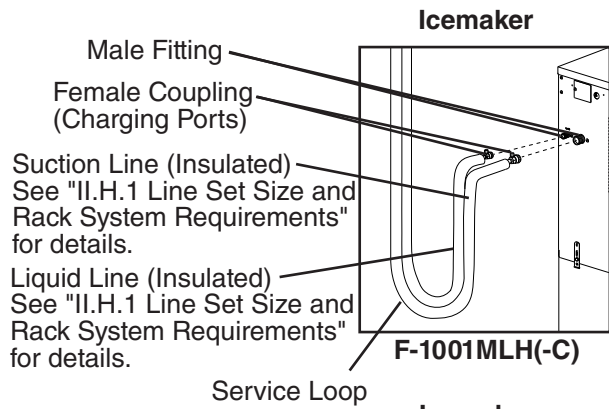
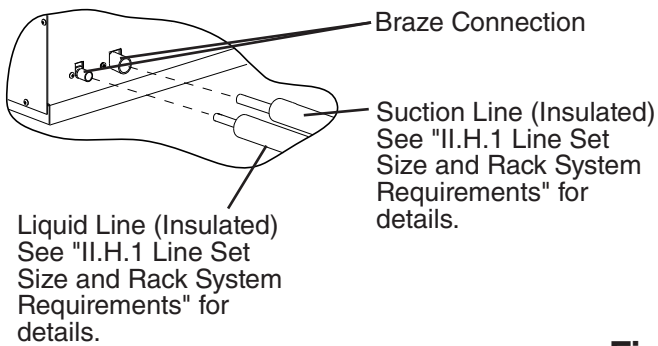

Fig. 15

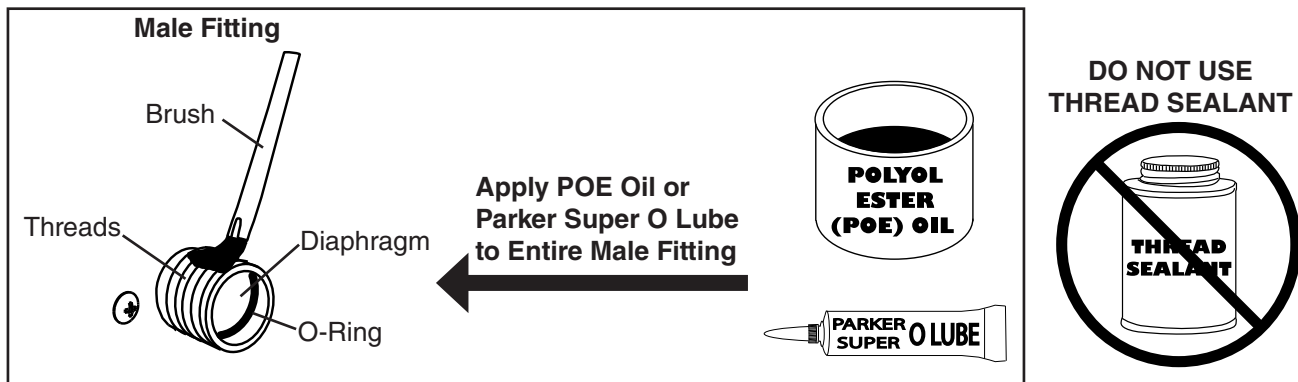

Fig. 16



Fig. 17

I. Final Checklist

WARNING

CHOKING HAZARD: Ensure all components, fasteners, and thumbscrews are securely in place after installation. Make sure that none have fallen into the dispenser unit/ice storage bin.

- 1) Is the icemaker level?
- 2) Is the icemaker in a site where the ambient temperature is within 45°F to 100°F (7°C to 38°C) and the water temperature within 45°F to 90°F (7°C to 32°C) all year around?
- 3) Is there at least 6" (15 cm) clearance at rear and sides and 24" (61 cm) at the top of the icemaker for proper air circulation ease of maintenance and service?
- 4) Have the shipping carton, tape, and packing material been removed from the appliance?
- 5) Have all electrical and water connections been made? Do electrical and water connections meet all national, state, and local code and regulation requirements?
- 6) Has the power supply voltage been checked or tested against the nameplate rating? Has a proper ground been installed to the icemaker? On remote models, has a proper ground also been installed to the remote condenser unit? On three phase models, has the transformer's voltage tap switch been positioned to match incoming voltage?
- 7) Are the water supply and drain lines sized as specified? Are the water supply line shut-off valve(s) and drain valve(s) installed? Has the water supply pressure been checked to ensure a minimum of 10 PSIG and a maximum of 113 PSIG?
- 8) Is the compressor snug on all mounting pads? Have the refrigerant lines been checked to make sure they do not rub or touch other lines or surfaces? Has the fan blade (if applicable) been checked to make sure it turns freely?
- 9) On remote and low side, parallel rack system models, is the line set tightened and free of leaks and kinks?
- 10) On remote models, has the appliance power supply been on for a minimum of 4 hours?
- 11) On remote models, is the remote condenser unit in a site where the ambient temperature is within -20°F to +122°F (-29°C to +50°C) all year around?
- 12) On remote models, is there at least 24" (61 cm) clearance around the remote condenser unit for proper air circulation and ease of maintenance and service?
- 13) Are all components, fasteners, and thumbscrews securely in place?
- 14) Has the end user been given the instruction manual, and instructed on how to operate the appliance and the importance of the recommended periodic maintenance?
- 15) Has the end user been given the name and telephone number of an authorized service agent?
- 16) Has the warranty card been filled out and forwarded to the factory for warranty registration?

J. Startup

⚠ WARNING

All parts are factory-adjusted. Improper adjustments may adversely affect safety, performance, component life, and warranty coverage.

NOTICE

- If the appliance is turned off, wait for at least 3 minutes before restarting the appliance to prevent damage to the compressor.
- At startup, confirm that all internal and external connections are free of leaks.
- On remote models, the appliance must have power for a minimum of 4 hours prior to startup to prevent compressor damage.

- 1) Open the water supply line shut-off valve(s).
- 2) Remove the front panel.
- 3) Move the control switch on the control box to the "ICE" position, then move the power switch to the "ON" position.
- 4) Replace the front panel in its correct position.
- 5) Turn on the power supply to start the automatic icemaking process.
- 6) Once the unit starts to produce ice, allow it to run for another 30 minutes.
- 7) Turn off the power supply, then remove the front panel.
- 8) Move the control switch to the "DRAIN" position, then replace the front panel in its correct position. Turn on the power supply and allow the water system to drain for 5 minutes.
- 9) Confirm bin control operation:
 - a) Turn off the power supply, then remove the front and top panels.
 - b) Move the power switch to the "OFF" position.
 - c) Remove the strap connecting the spout to the chute assembly. See Fig. 18. Pull up the chute assembly slightly so that you can access the actuator located in the top of the chute.
 - d) Move the control switch to the "ICE" position, then move the power switch to the "ON" position.

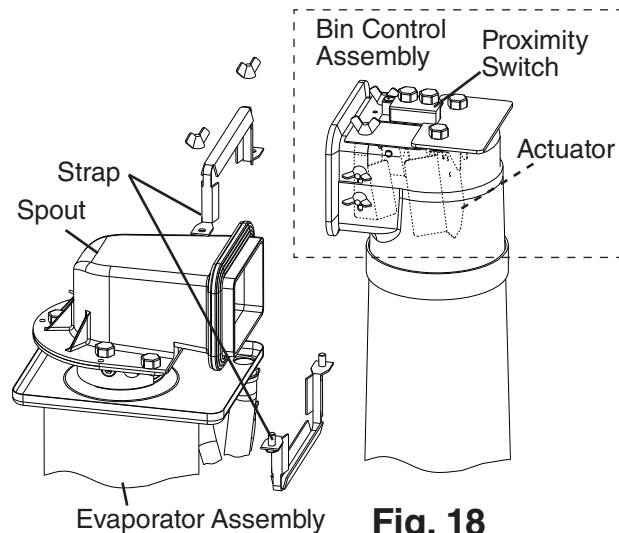

Fig. 18

- e) Turn on the power supply to start the automatic icemaking process. **WARNING! Keep hands, hair, and loose clothing clear of the cutter on top of the evaporator assembly.** Allow the icemaker to run until the compressor starts (approximately 60 seconds).
 - f) Press and hold the actuator paddle located in the top of the chute. The icemaker should shut down within 6 seconds.
 - g) Move the power switch to the "OFF" position, then turn off the power supply.
 - h) Replace the chute assembly and strap in their correct positions.
 - i) Move the power switch to the "ON" position.
 - j) Replace the top and front panels in their correct positions.
- 10) Pour warm water into the dispenser unit/ice storage bin and melt any remaining ice. Clean the dispenser unit/ice storage bin liner using a neutral cleaner. Rinse thoroughly after cleaning.
- 11) Turn on the power supply to start the automatic icemaking process.
- 12) On water-cooled models, confirm proper condenser drain outlet/return outlet temperature as outlined in "II.F.2. Water-Cooled Condenser."

III. Maintenance

The appliance must be maintained in accordance with the instruction manual and labels provided. Consult with your local Hoshizaki Certified Service Representative about maintenance service.

⚠ WARNING

- Only qualified service technicians should service the appliance.
- To reduce the risk of electric shock, do not touch the icemaker power switch or control switch with damp hands.
- **Before Servicing:** Move the icemaker's power switch to the "OFF" position. Turn off the power supply. Place the disconnect (if applicable) in the off position. Lockout/Tagout to prevent the power supply from being turned back on inadvertently.
- **CHOKING HAZARD:** Ensure all components, fasteners, and thumbscrews are securely in place after any maintenance is done to the appliance. Make sure that none have fallen into the dispenser unit/ice storage bin.

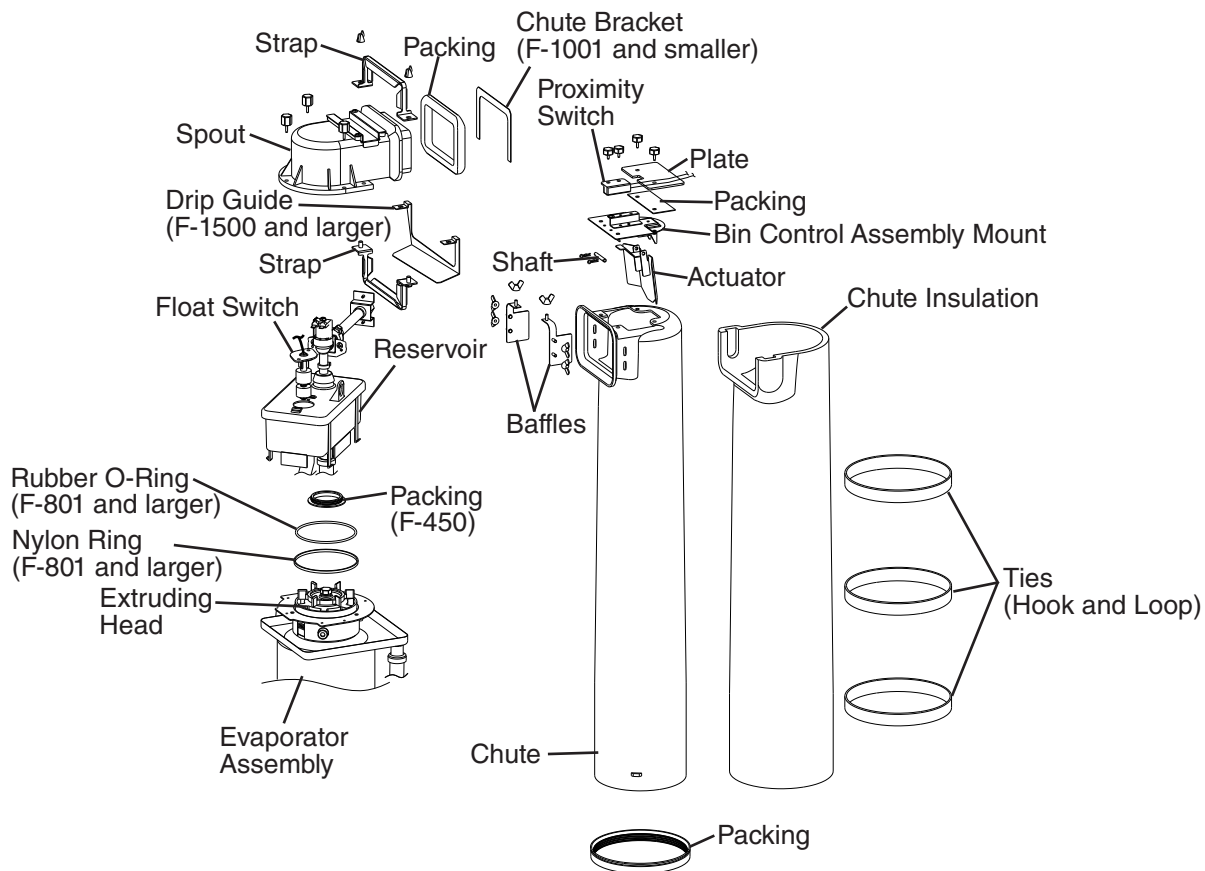

Fig. 19

**Model Shown:
F-1500MAH**

A. Maintenance Schedule

The maintenance schedule below is a guideline. More frequent maintenance may be required depending on water quality, the appliance's environment, and local sanitation regulations.

| Maintenance Schedule | | |
|----------------------------|---|---|
| Frequency | Area | Task |
| Daily | Scoop | Clean the ice scoop using a neutral cleaner. Rinse thoroughly after cleaning. |
| Bi-Weekly | Air Filters | Inspect. Wash with warm water and neutral cleaner if dirty. |
| Monthly | External Water Filters | Check for proper pressure and change if necessary. |
| | Icemaker Exterior | Wipe down with a clean, soft cloth. Use a damp cloth containing a neutral cleaner to wipe off oil or dirt build up. Clean any chlorine staining (rust colored spots) using a non-abrasive cleanser. |
| | Underside of Icemaker and Top Kits; Bin Door and Snout | Wipe down with a clean cloth and warm water. |
| Every 6 Months | Icemaker and Dispenser Unit/Ice Storage Bin | Clean and sanitize per the cleaning and sanitizing instructions provided in this manual. |
| | Evaporator Condensate Drain Pan and Gear Motor Drain Pan | Wipe down with a clean cloth and warm water. Slowly pour one cup of sanitizing solution (prepare as outlined in the sanitizing instructions in this manual) into the evaporator condensate drain pan. Be careful not to overflow the pan. The solution will flow down to the gear motor drain pan and out the drain line to sanitize these areas. Repeat with a cup of clean water to rinse. |
| | Icemaker and Dispenser Unit/Ice Storage Bin Drains | Check to make sure they are clear. |
| | Extruding Head Seal Bolts | Inspect for leakage around seal bolts. Tighten (see torque values below) or replace as necessary. Seal bolts must be replaced once removed because seal material is one-time use only. If new seal bolts do not have preapplied threadlocker, apply Loctite 243 or equivalent threadlocker to seal bolt threads. <ul style="list-style-type: none"> • <i>Torque for F-1001 and Smaller:</i> 11.1 ft-lb/15 N·m • <i>Torque for F-1500 and Larger:</i> 25.8 ft-lb/35 N·m Tighten 2 times. Allow at least 5 sec. in between each tightening. |
| Yearly | Inlet Water Valve and Drain Valve | Close the water supply line shut-off valve and drain the water system. Clean the inlet water valve screen and clean and inspect the drain valve. |
| | Water Hoses | Inspect the water hoses and clean/replace if necessary. |
| | Condenser | Inspect. Clean if necessary by using a brush or vacuum cleaner. |
| | Icemaker | Inspect for oil spots, loose components, fasteners, and wires. |
| | Upper Bearing (extruding head) | Check for wear using .02" round stock or pin gauge. Replace both upper bearing and lower bearing if wear exceeds factory recommendations. See the Service Manual for details. |
| After 3 Years, then Yearly | Upper Bearing (extruding head); Lower Bearing and O-Ring (lower housing); Mechanical Seal; Evaporator Cylinder; Auger | Inspect. Replace both upper bearing and lower bearing if wear exceeds factory recommendations. Replace the mechanical seal if the seal's contact surfaces are worn, cracked, or scratched. See the Service Manual for details. |

B. Cleaning and Sanitizing Instructions

The icemaker must be cleaned and sanitized at least twice a year. More frequent cleaning and sanitizing may be required in some conditions.

WARNING

- To prevent injury to individuals and damage to the icemaker, do not use ammonia type cleaners.
- Carefully follow any instructions provided with the cleaning and sanitizing solutions.
- Always wear liquid-proof gloves and goggles to prevent the cleaning and sanitizing solutions from coming into contact with skin or eyes.
- After cleaning and sanitizing, do not use ice made from the cleaning and sanitizing solutions. Be careful not to leave any solution on the parts or in the dispenser unit/ice storage bin.

1. Cleaning Solution

Dilute 9.6 fl. oz. (0.29 l) of Hoshizaki "Scale Away" with 1.6 gal. (6.0 l) of warm water. This is a minimum amount. Make more solution if necessary. **IMPORTANT! For safety and maximum effectiveness, use the solution immediately after dilution.**

2. Cleaning Procedure

- 1) Close the icemaker water supply line shut-off valve.
- 2) Turn off the power supply, then remove the front panel. Make sure the power switch is in the "ON" position, then move the control switch to the "DRAIN" position. Replace the front panel in its correct position.
- 3) Turn on the power supply and allow the water system to drain for 5 minutes.
- 4) Turn off the power supply, then remove the front and top panels. Move the power switch to the "OFF" position.
- 5) Remove all of the ice from the dispenser unit/ice storage bin.
- 6) Remove the strap connecting the spout to the chute assembly, then remove the spout. See Fig. 19.
- 7) Pour the cleaning solution over the extruding head until the evaporator assembly and the reservoir are full and the solution starts to overflow into the drain pan.
Note: If there is excess scale on the extruding head, fill the evaporator assembly and reservoir as described above, then use a clamp on the reservoir hose between the reservoir and evaporator assembly to block flow. Pour additional cleaning solution over the extruding head until the evaporator assembly is completely full.
- 8) Replace the spout and strap in their correct positions.
- 9) Allow the icemaker to sit for 10 minutes before operation. If you placed a clamp on the reservoir hose in step 7, remove it before operation.

- 10) In bad or severe water conditions, clean the float switch as described below. Otherwise, continue to step 11.
 - a. Remove the float switch from the reservoir cover.
 - b. Wipe down the float switch with the cleaning solution.
 - c. Rinse the float switch thoroughly with clean water.
 - d. Replace the float switch in its correct position.
- 11) Move the control switch to the "ICE" position, then move the power switch to the "ON" position. Replace the panels in their correct positions. Turn on the power supply and make ice using the solution until the icemaker stops making ice.
- 12) Turn off the power supply, then remove the front panel. Move the control switch to the "DRAIN" position, then replace the front panel in its correct position.
- 13) Turn on the power supply and allow the water system to drain for 5 minutes.
- 14) Turn off the power supply, then remove the front panel. Move the control switch to the "ICE" position, then replace the front panel in its correct position.
- 15) Open the icemaker water supply line shut-off valve, then turn on the power supply to supply water to the reservoir.
- 16) After the gear motor starts, turn off the power supply. Remove the front panel, then move the control switch to the "DRAIN" position. Replace the front panel in its correct position.
- 17) Turn on the power supply and allow the water system to drain for 5 minutes.
 Note: If you do not sanitize the unit, go to step 14 in "III.B.5. Sanitizing Procedure - Final."
- 18) Turn off the power supply, then close the icemaker water supply line shut-off valve.

3. Sanitizing Solution

Dilute 2.5 fl. oz. (74 ml or 5 tbs) of a 5.25% sodium hypochlorite solution (chlorine bleach) with 5 gal. (19 l) of warm water. This is a minimum amount. Make more solution if necessary. **IMPORTANT! For safety and maximum effectiveness, use the solution immediately after dilution.**

4. Sanitizing Procedure - Initial

- 1) Make sure the power supply is off and the icemaker water supply line shut-off valve is closed. Remove the front and top panels, then move the power switch to the "OFF" position.
- 2) Remove the strap connecting the spout to the chute assembly, then remove the spout. Remove the packing (F-450) or rubber O-ring and nylon ring (F-801 and larger) at the top of the cylinder and also remove the chute bracket (F-1001 and smaller) or drip guide (F-1500 and larger) and packing between the spout and chute.
- 3) Pour the sanitizing solution over the extruding head until the evaporator assembly and the reservoir are full and the solution starts to overflow into the drain pan.
- 4) Remove the proximity switch from the chute assembly, then remove the chute assembly from the icemaker.
- 5) Remove the packing at the bottom of the chute. Remove the 3 ties and the chute insulation.

- 6) Remove the 2 baffles.
- 7) Remove the plate and the packing from the top of the ice chute, then remove the bin control assembly by sliding it slightly towards the chute opening and lifting it off.
- 8) Disassemble the bin control assembly by removing the 2 snap pins, shaft, and actuator.
- 9) Soak the spout, rubber O-ring and nylon ring (F-801 and larger), packings, chute bracket (F-1001 and smaller), drip guide (F-1500 and larger), chute, baffles, plate, and bin control assembly in the sanitizing solution for 10 minutes then wipe them down.
- 10) Rinse the parts thoroughly with clean water. **NOTICE! If the solution is left on these parts, they will rust.**
- 11) Replace all parts in their correct positions. **IMPORTANT! When installing the baffles, make sure that the bent surface (the one without the studs) faces the actuator so that the bent surface can guide the ice to the center of the actuator.**
- 12) Move the control switch to the "ICE" position, then move the power switch to the "ON" position. Replace the panels in their correct positions, then turn on the power supply. Make ice using the solution until the icemaker stops making ice.
- 13) Turn off the power supply, then remove the front panel. Move the control switch to the "DRAIN" position, then replace the front panel in its correct position.
- 14) Turn on the power supply and allow the water system to drain for 5 minutes.
- 15) Turn off the power supply.

5. Sanitizing Procedure - Final

- 1) Mix a new batch of the sanitizing solution.
- 2) Make sure the power supply is off and the icemaker water supply line shut-off valve is closed. Remove the front and top panels, then move the power switch to the "OFF" position.
- 3) Remove the strap connecting the spout to the chute assembly, then remove the spout.
- 4) Pour the sanitizing solution over the extruding head until the evaporator assembly and the reservoir are full and the solution starts to overflow into the drain pan.
- 5) Replace the spout and strap in their correct positions.
- 6) Allow the icemaker to sit for 10 minutes before operation.
- 7) Move the control switch to the "ICE" position, then move the power switch to the "ON" position. Replace the panels in their correct positions, then turn on the power supply. Make ice using the solution until the icemaker stops making ice.
- 8) Turn off the power supply, then remove the front panel. Move the control switch to the "DRAIN" position, then replace the front panel in its correct position.
- 9) Turn on the power supply and allow the water system to drain for 5 minutes.
- 10) Turn off the power supply, then remove the front panel. Move the control switch to the "ICE" position, then replace the front panel in its correct position.
- 11) Open the icemaker water supply line shut-off valve, then turn on the power supply to supply water to the reservoir.

- 12) After the gear motor starts, turn off the power supply. Remove the front panel, then move the control switch to the "DRAIN" position. Replace the front panel in its correct position.
- 13) Turn on the power supply and allow the water system to drain for 5 minutes.
- 14) Turn off the power supply, then remove the front panel. Move the control switch to the "ICE" position, then replace the front panel in its correct position.
- 15) Turn on the power supply to start the automatic icemaking process. Allow the icemaker to run for 30 minutes, then turn off the power supply.
- 16) Pour warm water into the dispenser unit/ice storage bin and melt any remaining ice. Clean the dispenser unit/ice storage bin liner using a neutral cleaner. Rinse thoroughly after cleaning.
- 17) Turn on the power supply to start the automatic icemaking process.

IV. Preparing the Icemaker for Periods of Non-Use

| |
|---------------|
| NOTICE |
|---------------|

| |
|--|
| When storing the icemaker for an extended time or in sub-freezing temperatures, follow the instructions below to prevent damage. |
|--|

When the icemaker is not used for two or three days under normal conditions, it is sufficient to only move the power switch to the "OFF" position. When storing the appliance for extended time or in sub-freezing temperatures, follow the instructions below.

1. Remove the water from the icemaker water supply line:

- 1) Turn off the power supply, then remove the front panel.
- 2) Move the power switch to the "OFF" position.
- 3) Close the icemaker water supply line shut-off valve, then open the icemaker water supply line drain valve.
- 4) Allow the line to drain by gravity.
- 5) Attach a compressed air or carbon dioxide supply to the icemaker water supply line drain valve.
- 6) Move the control switch to the "ICE" position, then move the power switch to the "ON" position. Replace the front panel in its correct position, then turn on the power supply.
- 7) Blow the icemaker water line out using the compressed air or carbon dioxide supply.
- 8) Close the icemaker water supply line drain valve.

2. Drain the evaporator:

- 1) Turn off the power supply, then remove the front panel.
- 2) Move the control switch to the "DRAIN" position, then replace the front panel in its correct position.
- 3) Turn on the power supply and allow the water system to drain for 5 minutes.
- 4) Turn off the power supply, then remove the front panel. Move the power switch to the "OFF" position.
- 5) Remove the evaporator drain line hose from the evaporator and attach a compressed air or carbon dioxide supply to the hose.
- 6) Turn on the power supply, then move the power switch to the "ON" position. Blow out the evaporator drain line using the compressed air or carbon dioxide supply until water stops coming out.
- 7) Move the power switch to the "OFF" position, then turn off the power supply. Reconnect the evaporator drain line hose.
- 8) Move the control switch to the "ICE" position. Replace the front panel in its correct position.
- 9) Remove all ice from the dispenser unit/ice storage bin. Clean the dispenser unit/ice storage bin liner using a neutral cleaner. Rinse thoroughly after cleaning.

3. On water-cooled models, remove the water from the water-cooled condenser:

- 1) Make sure the power supply is off, then remove the front panel and right side panel.
- 2) Close the condenser water supply line shut-off valve. If connected to a closed loop system, also close the condenser return line shut-off valve.
- 3) Open the condenser water supply line drain valve. If connected to a closed loop system, also open the condenser return line drain valve.
- 4) Attach a compressed air or carbon dioxide supply to the condenser water supply line drain valve.
- 5) Open the water regulating valve by using a screwdriver to pry up on the spring retainer underneath the spring. While holding the valve open, blow out the condenser using the compressed air or carbon dioxide supply until water stops coming out.
- 6) Close the drain valve(s).
- 7) Replace the right side panel and front panel in their correct positions.

V. Disposal

The appliance contains refrigerant and must be disposed of in accordance with applicable national, state, and local codes and regulations. Refrigerant must be recovered by properly certified service personnel.

HOSHIZAKI AMERICA, INC.

618 Hwy. 74 S., Peachtree City, GA 30269 USA | TEL (770) 487-2331 | FAX (770) 487-3360 | www.hoshizaki.com | 1A2878-021