



Compact Vertical Contact Bun Toasters

Models:

#177CPBTR66A	120V • 1650W
#177CPBTR66B	208V • 2000W
#177CPBTR66D	240V • 2000W

Warning:

Improper installation, adjustment, alteration, service, or maintenance can cause property damage, injury, or death. Read the installation, operating, and maintenance instructions thoroughly before installing or servicing this equipment.

For Your Safety:

Do not store or use gasoline or other flammable vapors or liquids in the vicinity of this or any other appliance.

Note:

Please read and keep these instructions. Indoor use only.

Table of Contents

Critical Information	2
Hazard Statements	3
Initial Setup	5
Assembly	6
Cleaning.....	7
Operation	8
Maintenance	10
Troubleshooting.....	10

Critical Information

- **Use Only Non-Stick PTFE Release Sheet:** Only use the manufacturer-recommended non-stick PTFE release sheet. Using tinfoil or any other material can void the warranty and cause excessive heat buildup, a risk of fire, and damage to the equipment.
- **Proper Feeding:** Feed the buns into the unit with the sliced side facing inwards. Adjust sizing to allow for proper feeding. Failure to do so could result in burnt buns and risk of fire.
- **Secure Covers:** Ensure that the side panels and top lid are securely fitted and positioned before use for proper operation and safety.

#177CPBTR66A



#177CPBTR66B & #177CPBTR66D



CONFORMS TO NSF/ANSI STD. 4
CONFORMS TO UL STD. UL-197

Hazard Statements

Key Safety Warnings

SYMBOLS



WARNING - To prevent personal injury.



CAUTION - Hot surface, burn risk.

ELECTRICAL HAZARDS

WARNING – Electric Shock (Liquid Entry)

- Water and other liquids entering the inside of the equipment can create electrical hazards.
- Keep water and other liquids from entering the inside of the equipment.
- Avoid allowing any liquid to penetrate the equipment's exterior.
- Liquid inside the equipment could cause an electrical shock.

WARNING – Electric Shock (Spray Cleaning)

- Direct application of liquids to the unit can damage electrical components.
- Do not spray water or cleaning products directly onto the unit.
- Avoid using spray bottles or pressurized cleaning systems on the equipment.
- Liquid could contact the electrical components and cause a short circuit or an electrical shock.

WARNING – Electrical Hazard / Fire Hazard (Power Cord)

- Damaged or modified power cords create significant electrical risks.
- Do not use equipment if the power cord is damaged or has been modified.
- Avoid using equipment with frayed, cracked, or otherwise compromised power cords.
- Using equipment with a damaged or modified cord could result in electric shock, fire, or injury.

WARNING – Electrical Hazard / Fire Hazard (Hot Surfaces)

- Power cords contacting hot surfaces may have their insulation compromised.
- Ensure that the power supply cord does not come into contact with hot surfaces.
- Avoid routing power cords near or across heating elements or hot components.
- Contact with hot surfaces could damage the cord and result in fire or electric shock.

WARNING – Electrical Hazard (Water Cleaning)

- Improper cleaning methods can introduce water to electrical components.
- This appliance should not be cleaned with a water jet or immersed in water.
- Avoid using pressure washers, sink immersion, or direct water application for cleaning.
- Cleaning with a water jet or immersing the appliance could cause damage or an electrical hazard.

WARNING – Electric Shock (Cleaning)

- Cleaning while connected to power creates shock hazards.
- Ensure that the toaster is disconnected from the power supply before cleaning.
- Avoid cleaning the appliance while it is plugged in or still connected to power.
- Failure to disconnect power before cleaning could result in electric shock.

CAUTION – Fire and Electric Shock (Cord Replacement)

- Non-original replacement cords may not meet safety specifications.
- Replace only with manufacturer's cord set.
- Avoid using generic or non-approved replacement power cords.
- Increased risk of fire or electric shock may result from using incorrect cord sets.

BURN HAZARDS

WARNING – Hot Surfaces (Operation)

- The toaster contains surfaces that reach high temperatures during normal operation.
- Take care when operating the unit, as there will be hot surfaces.
- Avoid touching the exterior of the toaster during and immediately after operation.
- Contact with hot surfaces can cause serious burns.

WARNING – Residual Heat

- Equipment may remain hot after power indicators are off.
- Be aware that the equipment may be hot, even though the pilot light is not on.
- Avoid assuming the unit is cool simply because indicators are off.
- Touching the equipment when it is hot could result in burns.

WARNING – Hot Surfaces (Maintenance)

- Immediate cleaning or maintenance can lead to contact with hot surfaces.
- Allow the unit to cool for 30 minutes before cleaning or performing maintenance.
- Avoid cleaning the unit immediately after operation.
- Failing to allow the unit to cool could result in burns from hot surfaces.

GENERAL SAFETY

WARNING – Fire Hazard / Equipment Damage (Materials)

- Improper materials can cause excessive heat buildup and fire hazards.
- Do not use tinfoil or any other material as a substitute for the non-stick PTFE release sheet.
- Avoid improvising with non-approved materials in the toaster.
- Using tinfoil will create excessive heat buildup, cause buns to stick, create a risk of fire, lead to premature failure of elements, and void the warranty.

WARNING – Injury Risk (Children)

- Children may not understand equipment hazards and may be injured.
- Supervision is necessary when the appliance is used in close proximity to children.
- Avoid allowing children near operational equipment without close supervision.
- Failure to supervise children near the appliance could result in injury.

WARNING – Unattended Operation

- Unattended equipment may develop hazards without timely intervention.
- Do not operate unattended.
- Avoid leaving the toaster running without someone present to monitor it.
- Operating the unit unattended could lead to hazards occurring without timely intervention.

WARNING – Malfunction Risk

- Damaged or malfunctioning equipment presents multiple hazards.
- Do not operate if the equipment has been damaged or is malfunctioning in any way.
- Avoid attempting to use equipment that shows signs of damage or improper operation.
- Operating damaged or malfunctioning equipment could result in injury, fire, or further damage.

WARNING – Injury Risk (Instructions)

- Lack of proper understanding increases risk of injury.
- Read all instructions before use.
- Avoid operating the equipment without first reviewing all safety information.
- Failure to follow these precautions could result in injury to yourself and others.

Initial Setup

- **Inspect the Packaging:** Examine the unit's packaging for any signs of damage that may have occurred during shipping.
- **Unboxing:** Open the packaging with care.
 - Use scissors or a box cutter to cut open the box.
 - Ensure you do not damage the unit or its components.
 - If any damage is noticed, contact customer service immediately.
- **Placement**
 - Place the unit on a stable surface near an electrical outlet.
 - Level placement is crucial for the unit to work effectively.
 - **CAUTION** – To reduce the risk of fire, the appliance is to be mounted on floors of noncombustible construction with noncombustible flooring and surface finish and with no combustible material against the underside thereof, or on noncombustible slabs or arches having no combustible material against the underside. Such construction shall in all cases extend not less than 8 inches beyond the equipment on all sides.
- **Electrical Connection**
 - **Dedicated Circuit:** Use only a GFCI dedicated circuit to power this equipment.
- **GFCI Troubleshooting**
 - A GFCI receptacle protects against "ground faults" whenever an electrical product is plugged into the GFCI outlet by constantly monitoring the electricity for any loss of current. If your GFCI outlet trips:
 - The heater element may absorb some moisture into its casing and insulation during shipment or during long periods of not being used.
 - Plug the unit into a non-GFCI outlet, set the temperature to "MAX" and let it run for 15-30 minutes to dry out any moisture the element may have absorbed.
 - After drying the element, plug the unit into the GFCI outlet; the unit should run without tripping the GFCI.
 - If the unit still trips the GFCI, call RKW warranty provider.

Assembly

BUTTER ROLLER ATTACHMENT (OPTIONAL ACCESSORY)

1. **Insert Tabs:** Insert the two tabs at the rear of the roller tray into the slots located on the top cover and allow the tray to rest against the front of the top cover (Fig. 1A).
2. **Place Roller:** Place the removable roller onto the two cradles inside the roller tray (Fig. 1B).

NON-STICK PTFE RELEASE SHEET

1. **Locate Non-Stick PTFE Release Sheet:** Remove the included non-stick PTFE release sheet from the packaging and prepare for installation.
2. **Fold:** Reference the graphic for how to properly fold the non-stick PTFE release sheet (Fig. 2).
3. **Install:** Install the non-stick PTFE release sheet into the toaster by holding the folded side and sliding it in directly down over the center plate of the toaster (Fig. 3). Make sure both sides are still flat and making proper contact.

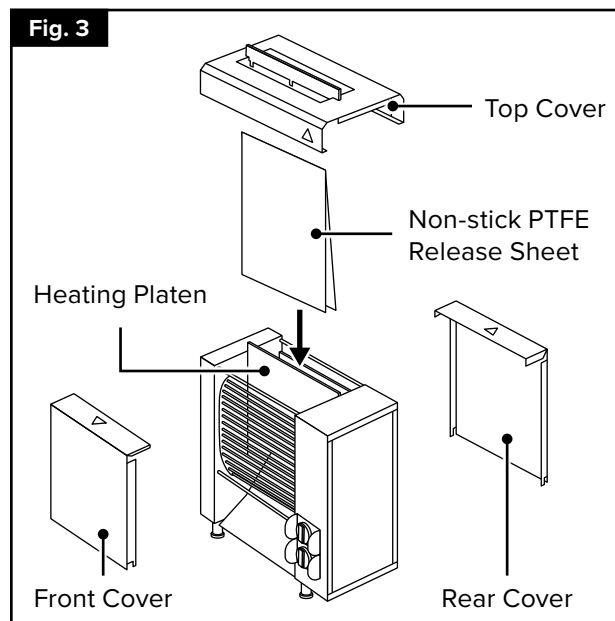
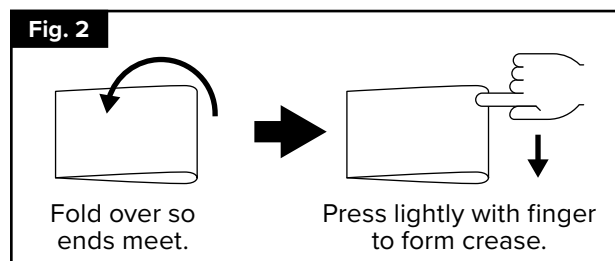
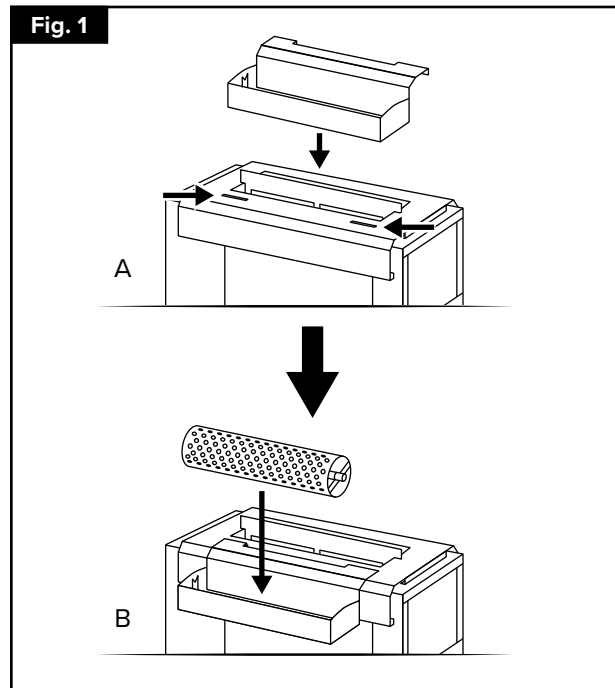

Cleaning

- **Caution:** The toaster must be unplugged and cool before cleaning.
- **Do not clean** with a water jet or immerse the appliance in water. Use only a damp cloth or sponge dipped in soapy water.
- **Exterior Cleaning:** Clean the exterior with a stainless steel cleaner and a soft cloth or brush. Remove oil and build up. Do not use abrasive tools like steel wool.
- **Wipe the Chute:** Clean out the area under the chains where the non-stick PTFE release sheet meets the stainless steel body. Excess buildup can cause buns to get stuck.
- **NOTE:** Cleanliness of the unit's conveyor belt and platen will impact performance and consistency.

CLEANING THE RELEASE SHEET

1. Turn off the power, unplug the unit, and allow it to cool for 30 minutes.
2. Remove the top cover, remove the front cover, then remove the release sheet and place on a clean, dry surface.
3. Wipe the surface of the release sheet with a clean towel dampened with multi-purpose detergent solution, followed by a clean towel dampened with sanitizer.
4. Allow the unit to dry and then repeat the cleaning process on the other side.
5. Drape the release sheet over both sides of the heating plate when completely dry.
6. Replace the front panel and then the top cover.

Operation

CONTROLS AND ADJUSTMENTS

- **Front Controls:** The front panel features controls for temperature and conveyor speed.
 - **Temperature Control (Fig. 4A):** A thermostatically controlled knob allows setting the temperature between 122°F and 572°F.
 - **Conveyor Speed (Fig. 4B):** Turn the speed knob to adjust the speed of the conveyor belts.
 - **Indicator Light (Fig. 4C):** The indicator light signals that the elements are on and heating.
- **Side Controls:** The side panel features controls for gap adjustment.
 - **Gap Adjuster Knobs (Fig. 5A):** Located on the left side, these knobs adjust the distance between the conveyor and the heating plate.
 - **Crown and Heel:** Depending on the bun type being toasted, adjust the two knobs to properly press the crown and heel against the non-stick PTFE release sheet.
 - **Size Guide (Fig. 5B):** Reference the size guide on the unit to get a general idea and adjust from there. The MIN setting is for 1/2" halves, while the MAX setting is for 1 3/8" halves.

CHUTE ANGLE

- **Chute Angle:** The exit chute position can be adjusted using the bars on the toaster body.

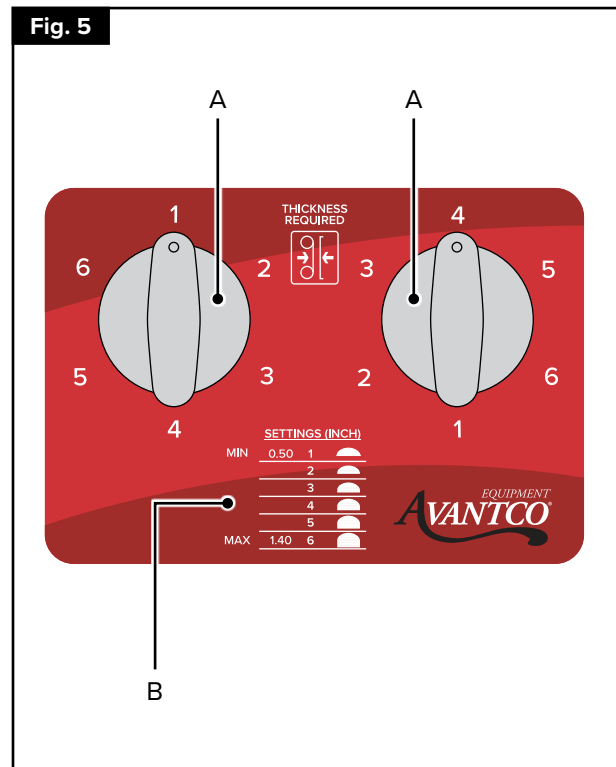
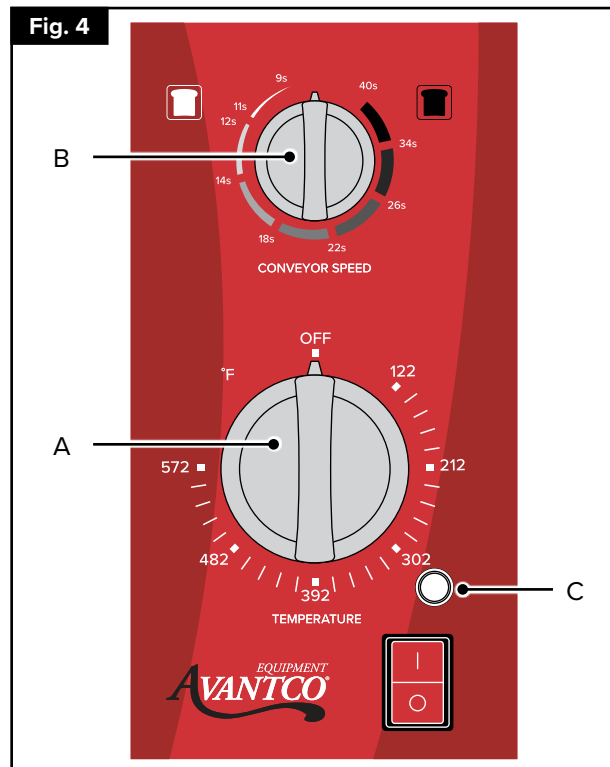

STARTUP PROCEDURES

- **Power On:** Plug in the unit and turn the switch to ON.
- **Heating:** When switched on, the indicator light will illuminate, indicating the heating elements are on and heating.
- **Heating Period:** Initial heating will take approximately 15 minutes.
- **Start Toasting:** Once the light turns off, the unit has reached operating temperature and is ready for use.

STANDARD OPERATION

1. Confirm that the non-stick PTFE release sheet is in place over the center plate that houses the heating elements.
 2. Ensure the side panels and top lid are securely fitted.
 3. Set the desired temperature using the thermostatically controlled knob (range 122°F to 572°F).
 4. Set the desired conveyor speed via the knob on the front panel.
 5. Adjust the thickness settings as needed.
 6. Wait until the indicator light goes out, indicating the unit has reached the set temperature.
 7. Feed buns into the toaster opening. Make sure that the crown and heel are fed into the proper sides.
- **NOTE:** The toasted color of the bun can be adjusted lighter or darker by using the temperature control, the speed control, or a combination of both. When optimal bun color and speed have been achieved, it is recommended to take note of the settings for future reference.
 - **NOTE:** Should the temperature setting be changed, allow several cycles for the plate to adjust.

SHUTDOWN PROCEDURES

- **Power Off:** Turn off the unit and unplug when not in use.

Maintenance

DAILY TASKS

1. Clean the unit per instructions in “Cleaning” section.
2. Check the non-stick PTFE release sheet (see section below).

NON-STICK PTFE RELEASE SHEET

- Remove and discard the old release sheet. Lay a new release sheet on a clean, dry surface and fold it in half lengthwise, gently creasing it at the fold using only your fingers. Install the release sheet draped over both sides of the heating plate.
- The lifespan of the non-stick PTFE release sheet is typically between 45–60 days depending on usage and daily cleaning. It should be replaced if any of the following are true:
 - Non-stick PTFE release sheet is worn or damaged.
 - Buns are not passing smoothly over the heating plate.
 - Buns are sticking to the plate.
- A worn or damaged non-stick PTFE release sheet will stick to the heating plate, causing improper toasting and potential damage to the heating elements.

Troubleshooting

Problem	Possible Causes	Action
Unit will not operate.	Power cord is damaged or has been modified.	Replace the supply cord with a new cord assembly available from the supplier's agent.
Unit is overheating.	Safety thermostat has automatically switched off the unit.	Reset the safety thermostat. Locate the thermostat at the rear of the unit near the power cord entry. Unscrew the cap and press the button.